

ARCH1101

TESTING +

EVALUATION

RUSSELL LOWE

As the video files that accompany this lecture are large they have been uploaded to the ARCH1101 course folder on the FBE networks S drive here:

ARCH1101/Resources/Lectures/Lecture_12_TestingAndEvaluation



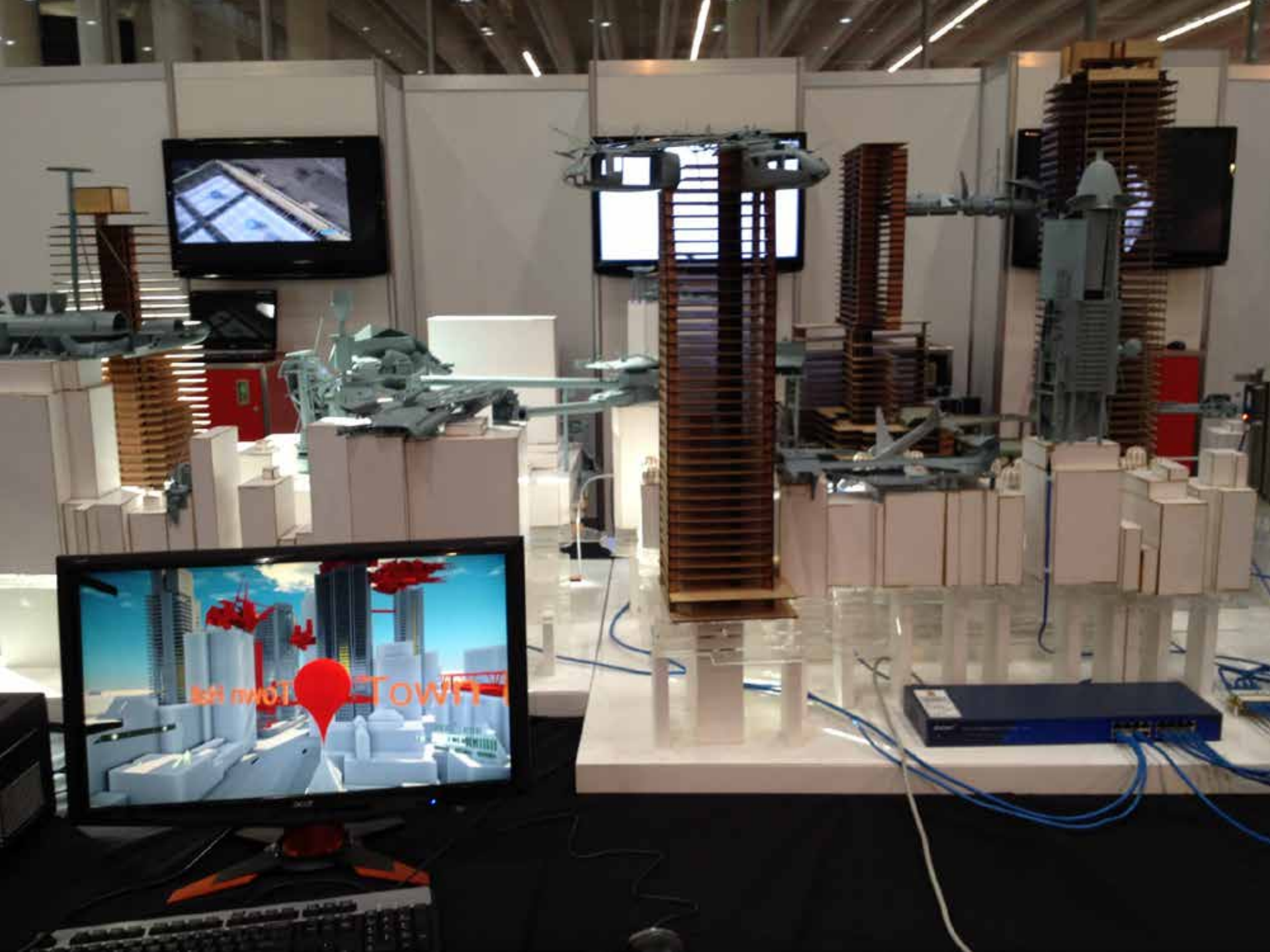

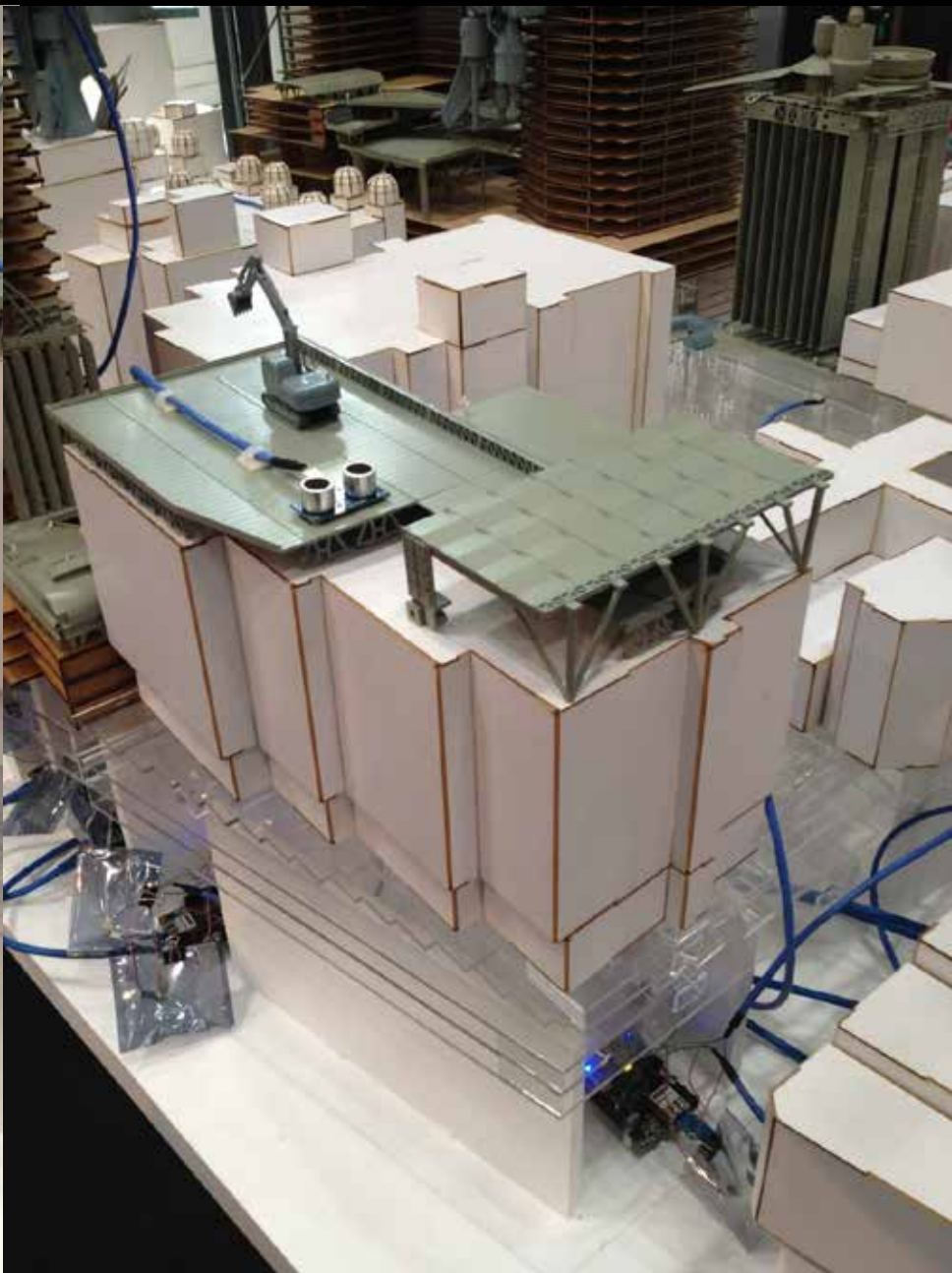
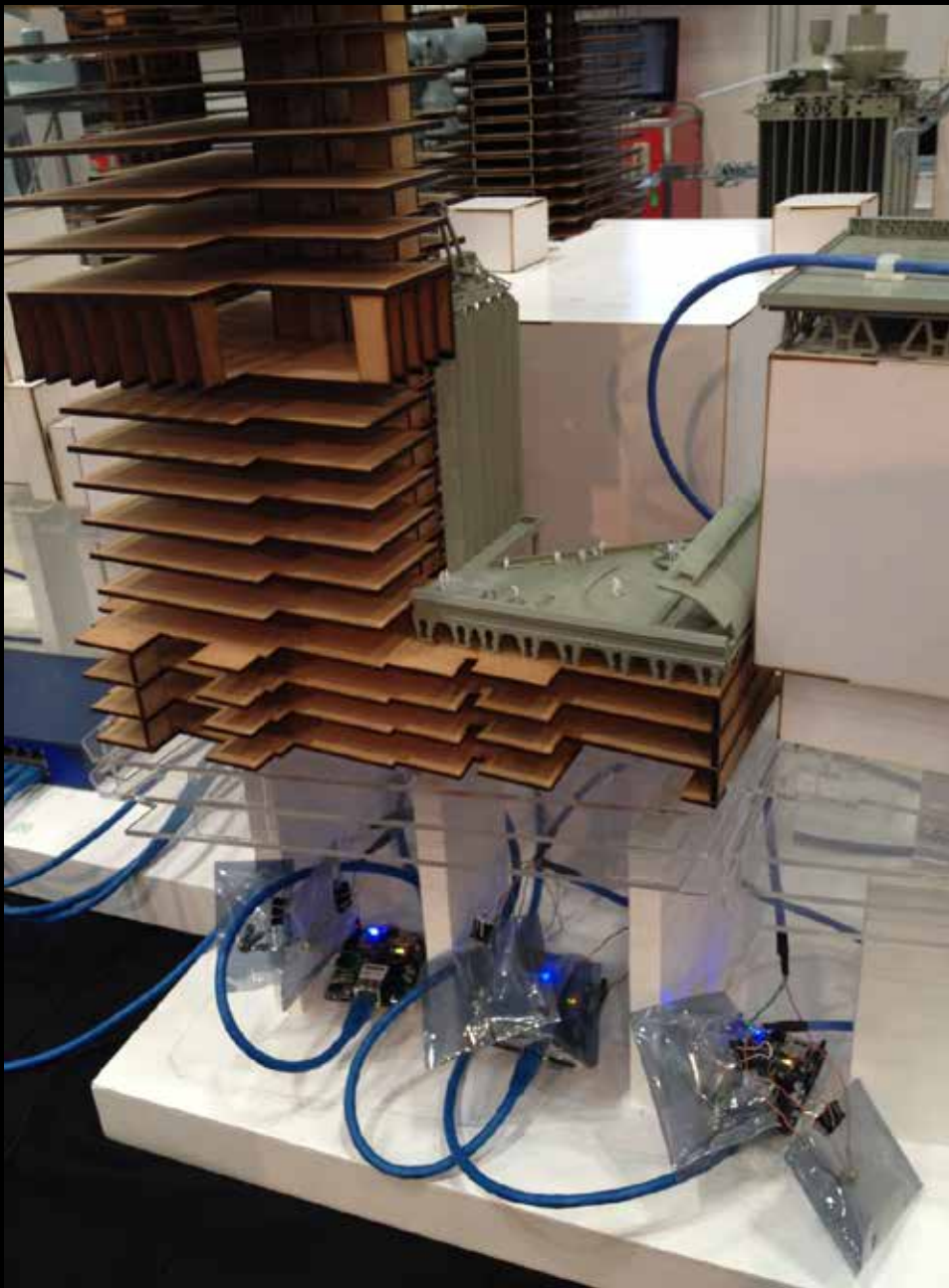

REAL TIME POROSITY

RICHARD GOODWIN + RUSSELL LOWE + EICU

WITH JULIAN CROMARTY, VINH NGUYEN, JOSH HARLE AND SAMANEH MOAFI

00:00:03











john varvatos

315 Bowery

Black

CoLab: John Varvatos + Road Recovery + Black

Black motorcycles take universal motorcycles and transform them into machines that riders create unique experiences with.

Proposal: a Black motorcycle with John Varvatos leather (seat, gaitors, grips, detailing) auctioned by Road Recovery.



john varvatos







THE BLACK MOTORCYCLES

John Lambert

SERIES 1000

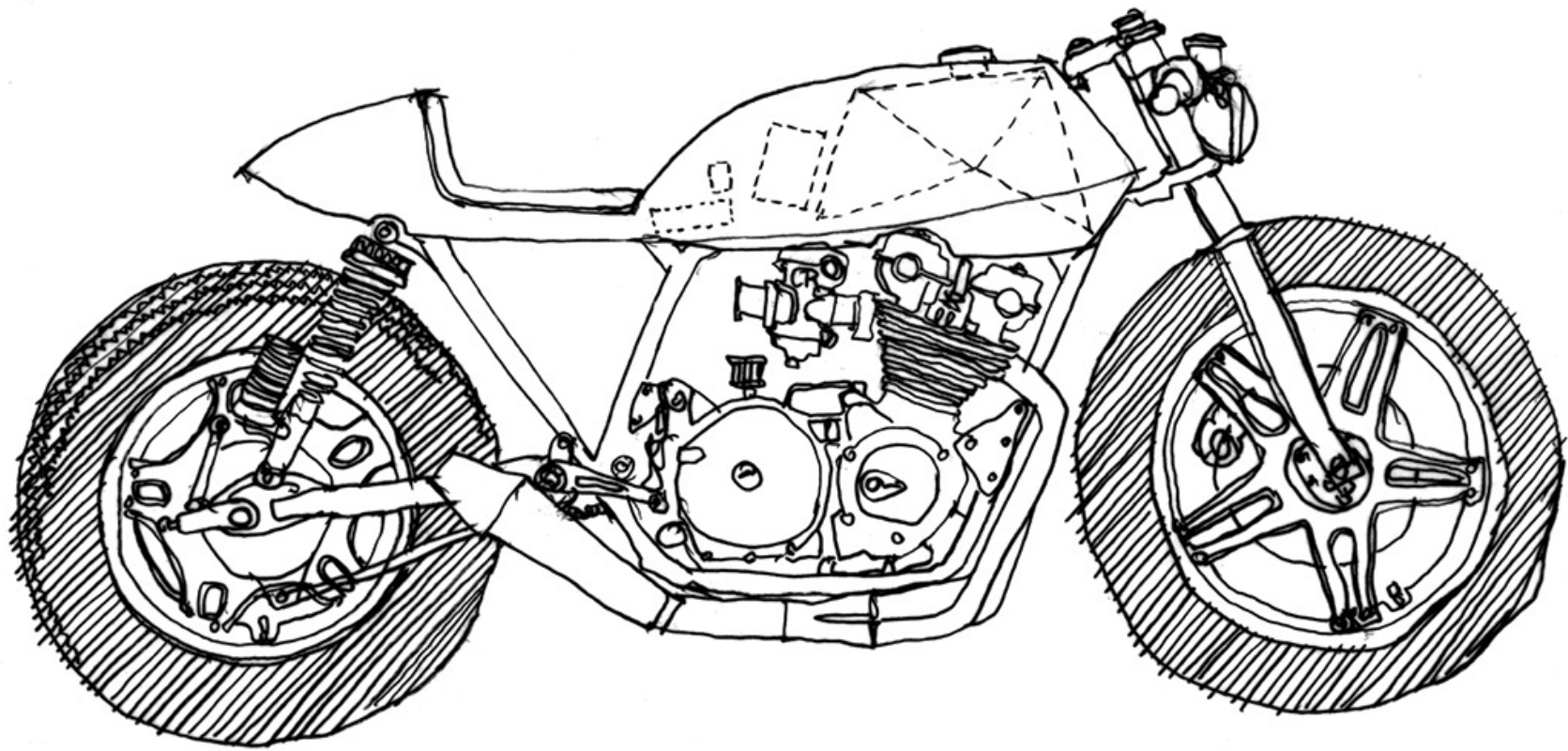

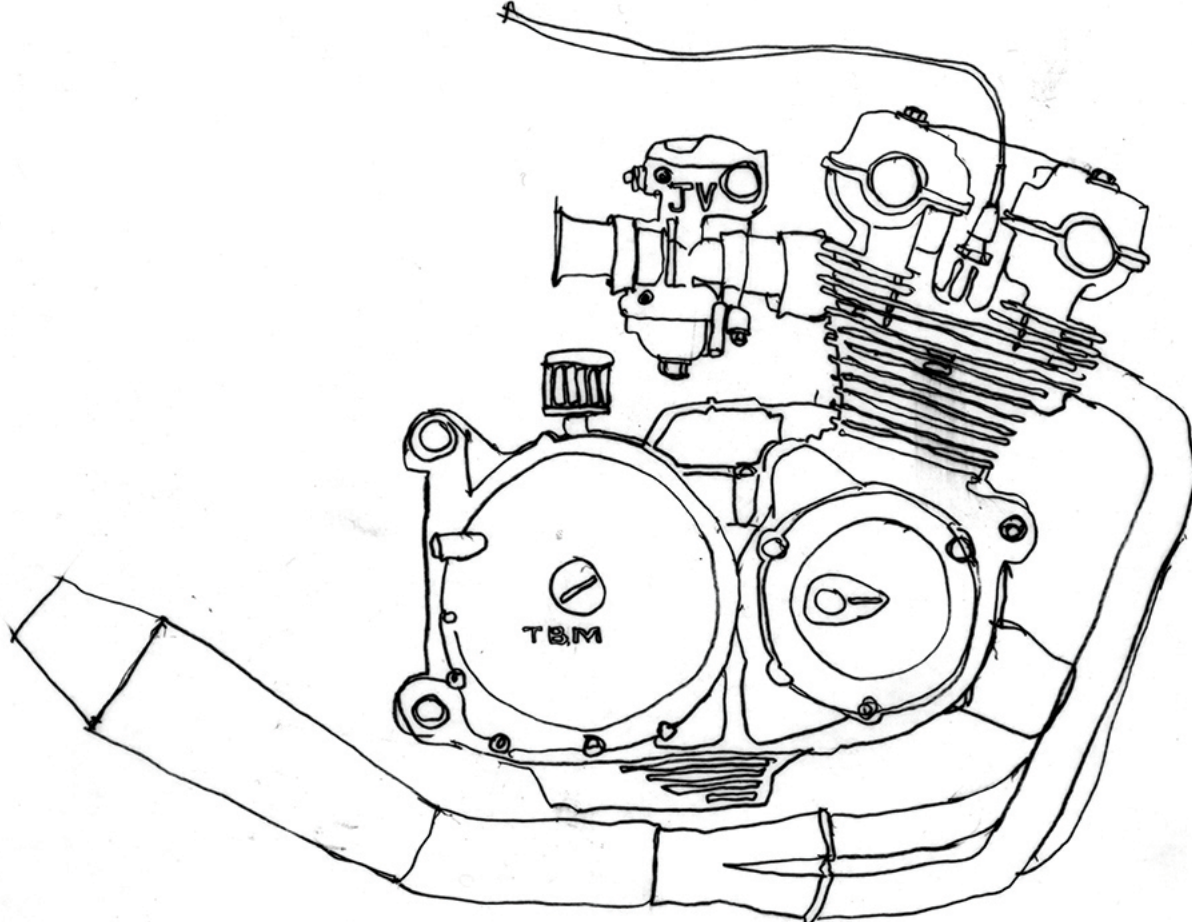











TESTING

Who designed the "House at Bordeaux"?

Which of these stairs is cantilevered?

In the lecture on Sections which Architects work is the odd one out?

What are the two contrasting materials used in the stair created by Luis Barragan?

Who designed this building?

Where is this building by OMA located?

Which lecture was this image shown in?

Which Indian-born British sculptor created this work?

How is the texture created on the surface of this stair?

What did Bernard Tschumi say was the most architectural thing about Le Corbusier's Villa Savoy?

TESTING

What kind of animal was the sis airlift in the lecture on action interaction and reaction?

The drawing of the Villa Maria in lecture 10 was a ... ?

The grand tour is like a ...?

According to Greg Lynn the decimal point was invented in what century?

What new video game was recommended by the student in lecture 4?

TESTING

BENV2423

TESTING + EVALUATION

MATHEW HUNTER



BARCELONA PAVILION

JASON WONG



RUDIN HOUSE

YEN NGUYEN

HANFEI TU

ARCH7202

TESTING + EVALUATION

JULES CROMARTY

EVAN FREEMAN

HARRY LEGASPI

ROS KEMBER

ARCH1101 EXP3

TESTING + EVALUATION

MATT O'BRIEN 01

MATT O'BRIEN 02

MATT O'BRIEN 03

MATT O'BRIEN 04

TESTING + EVALUATION

YEHUDA BASSIN 1

YEHUDA BASSIN 2

YEHUDA BASSIN 3

JAMES HARGRAVES

EDWARD ROSIER

YIMING SONG

HAYDEN WOLDRIDGE

TESTING + EVALUATION

JUSTIN BUCKWELL

ANDREW BEST

MORGAN CARSON

TAI DANH LIEN

MENG LI

MASAYU MASAGOS

TODAY'S STUDIO

1. During this studio session each tutor will review your full draft of the outcomes required for EXP3. See the **OUTPUTS** section of the EXP3 brief for what is required; a full draft includes all of those outputs. While each of the outputs might not be finished they do need to present a clear indication of the strengths and opportunities of the scheme. This is verbal feedback.

TODAY'S STUDIO

1. During this studio session each tutor will review your full draft of the outcomes required for EXP3. See the OUTPUTS section of the EXP3 brief for what is required; a full draft includes all of those outputs. While each of the outputs might not be finished they do need to present a clear indication of the strengths and opportunities of the scheme. This is verbal feedback.

TODAY'S STUDIO

2. In addition to the feedback received from your tutor above each student will ask 2 other students to review their work on the marking schedules provided. Comments and an indicative grade should be included. It's important that these are accurate! The students reviewing your work need not be in your tutorial group.

QUESTIONS?