

**ELECTROLIQUID
AGGREGATION +
LAZINESS +
RECYCLING +
SCULPTURAL
MATHEMATICS**

RUSSELL LOWE

**ELECTROLIQUID
AGGREGATION +
LAZINESS +
RECYCLING +
SCULPTURAL
MATHEMATICS**

JEREMY HARKINS

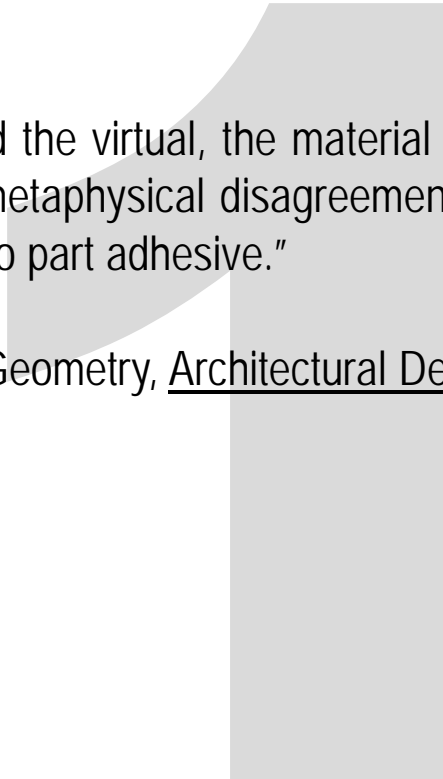

"Why still speak of the real and the virtual, the material and immaterial? Here these categories are not in opposition, or in some metaphysical disagreement, but more in an electroliquid aggregation, enforcing each other, as in a two part adhesive."

Lars Spuybroek, [1998] Motor Geometry, Architectural Design, Vol 68 No 5/6, p5

LARS SPUYBROEK

CAUTION
KEEP OUT OF REACH OF CHILDREN
READ SAFETY DIRECTIONS BEFORE OPENING

SELLEYS®

Araldite®



5 minute
everyday
EPOXY ADHESIVE

- EVERYDAY USE
- EASY MIX
- RIGID BOND

FOR USE ON:
• CHINA
• METAL
• GLASS
• LEATHER
• RUBBER
• MOST PLASTICS

Araldite®
STRENGTH

24mL

24mL

ARALDITE® GLOBAL TECHNOLOGY AND INNOVATION

DO NOT MIX WITH
OTHER BRANDS OF
EPOXY ADHESIVES
OR OTHER BRANDS OF
EPOXY RESIN

Neutelings and Riedijk *ON laziness recycling sculptural mathematics & ingenuity.*
El croquis 94.

“Laziness, one of the seven cardinal sins, is one of (a designers) most useful characteristics. The combination of diligence and ambition is highly dangerous; the combination of laziness and ambition ensures a pleasing balance, which often leads to happy results because compensating for laziness requires the application of ingenuity.”

Recycling Typologies and Concepts.

Sculptural Mathematics: “The most exhausting sort of design process is one in which each version requires a conscious decision. We therefore make it our practice to start off with a simple basic mathematical concept within which the program is to be organized.”

Conclusion: “... no matter how successful it might be as a method, (laziness) still has a great disadvantage: it requires a lot of effort.”

NEUTELINGS + RIEDIJK

MINNAERT BUILDING. UTRECHT.

Neutelings and Riedijk. El croquis 94.

NEUTELINGS + RIEDIJK

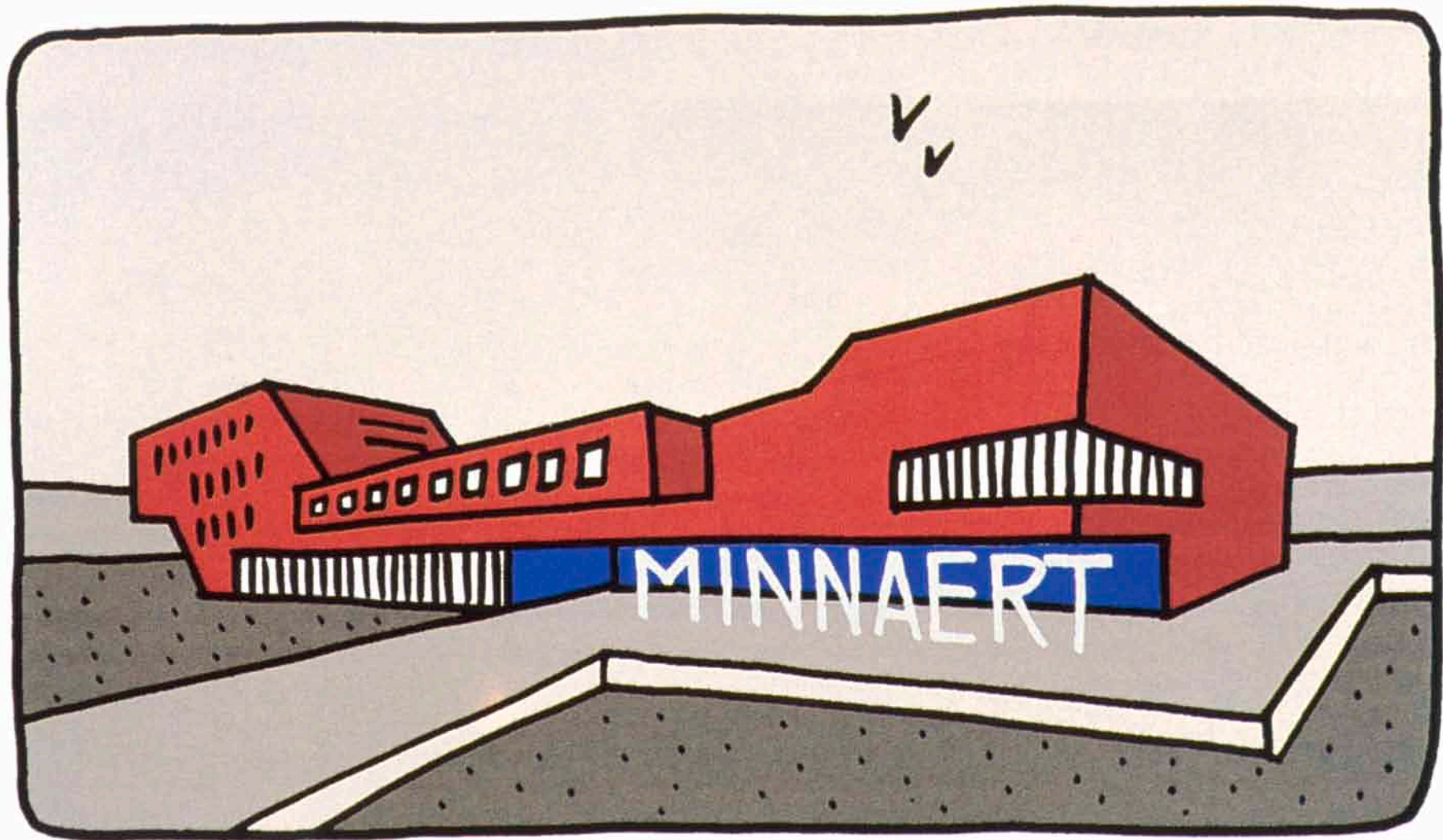



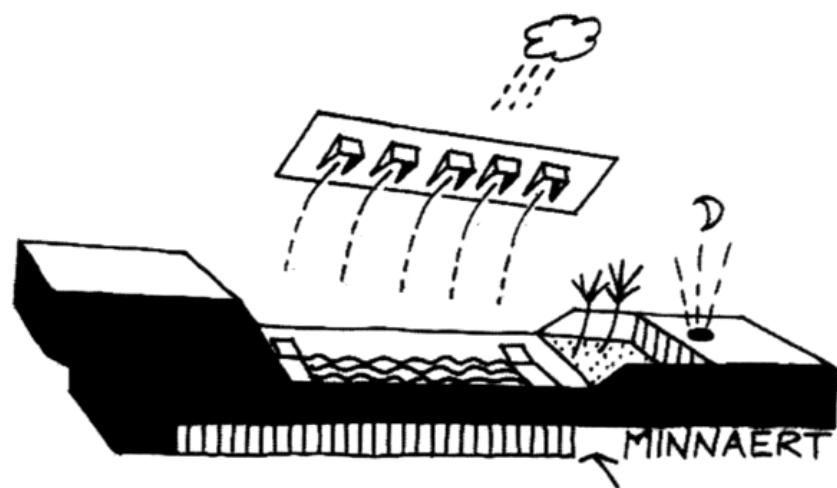
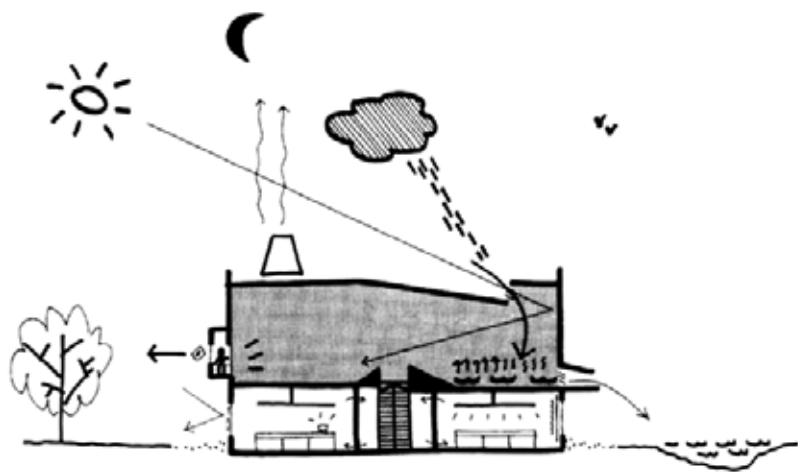





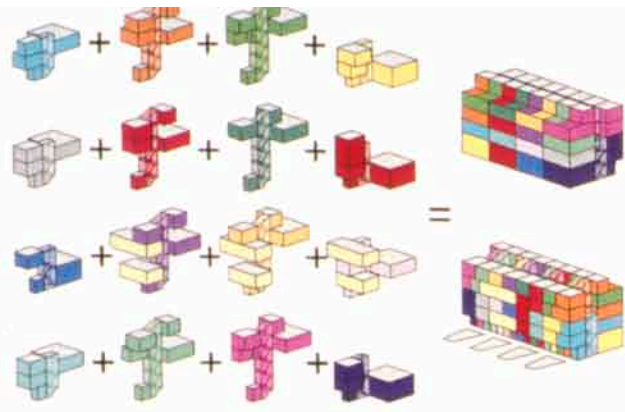

GWL AMSTERDAM

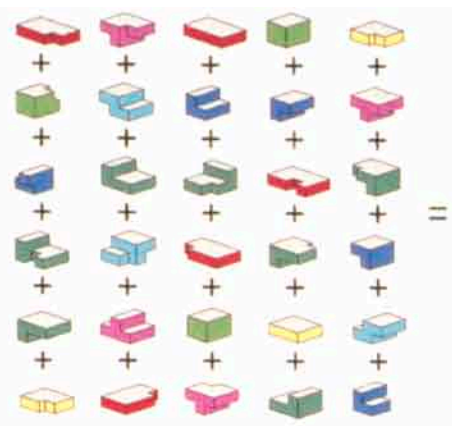

DEN HAAG

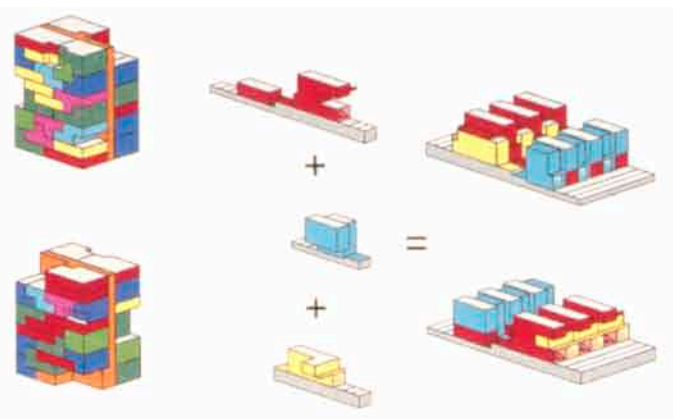

BORNEO SPORBURG

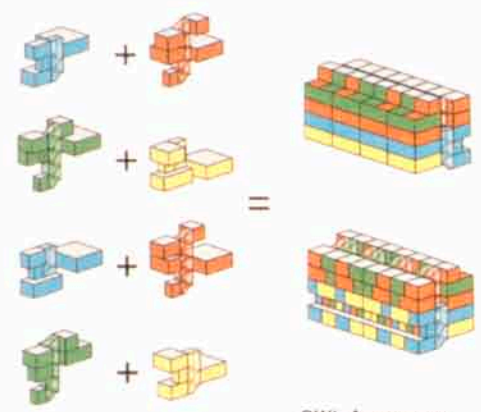

GWL AMSTERDAM

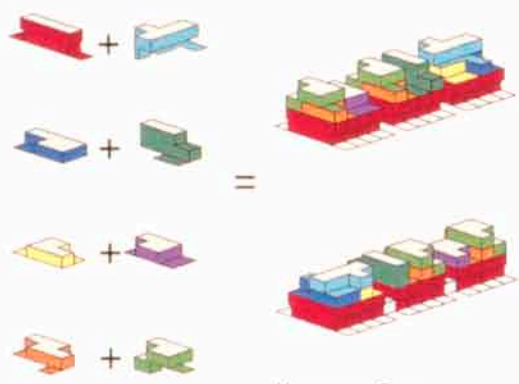

HOLLAINHOF GENT

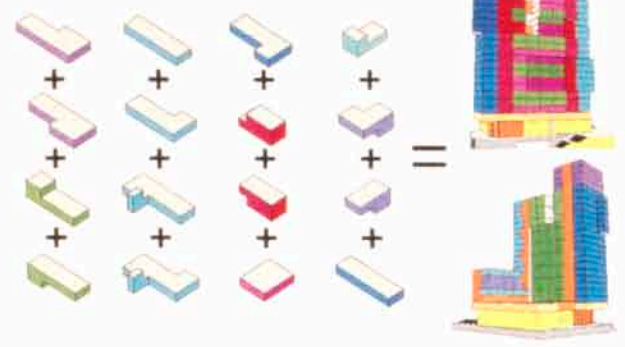

WIJNHAVEN ROTTERDAM

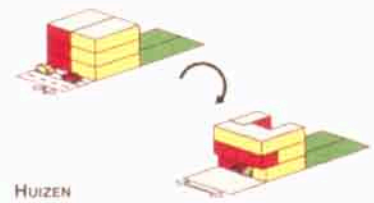
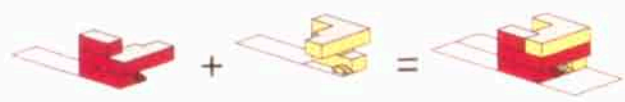

HUIZEN

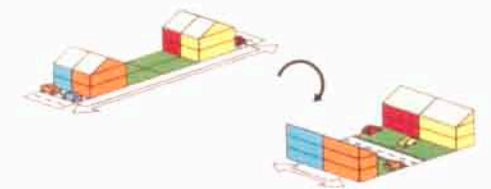

IJSSELSTEIN

Diferentes estudios volumétricos/tipológicos para viviendas
 Different volumetric/typological studies for dwellings

SCULPTURAL MATHEMATICS

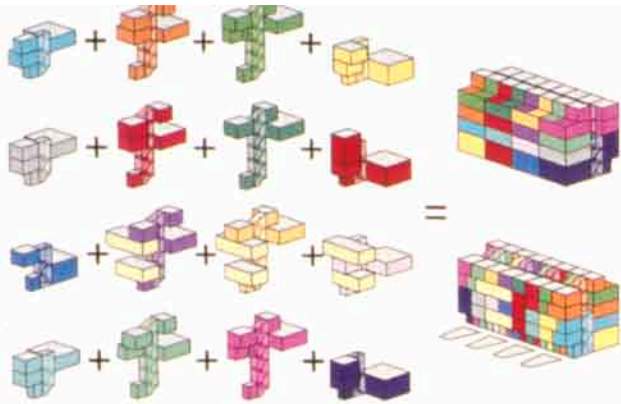

GWL AMSTERDAM

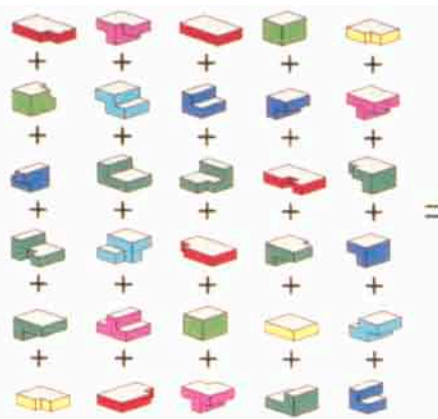

DEN HAAG

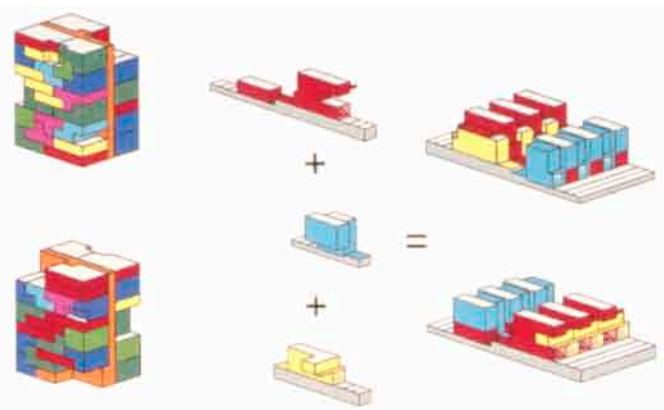

BORNEO SPORENBURG

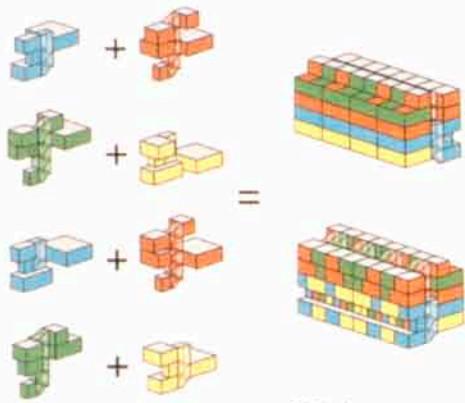

GWL AMSTERDAM

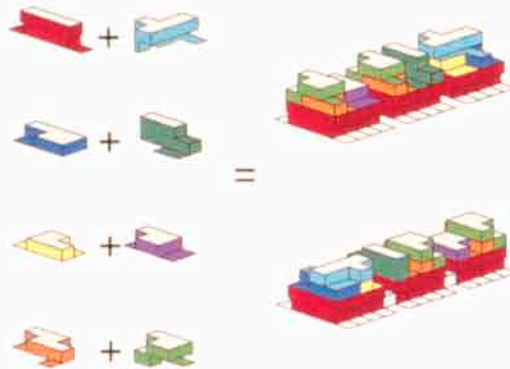

HOLLAINHOF GENT

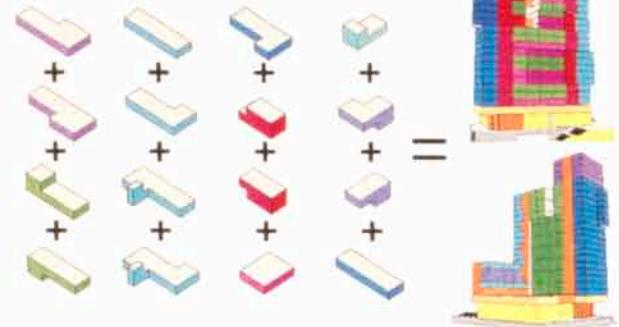

WIJNHAVEN ROTTERDAM

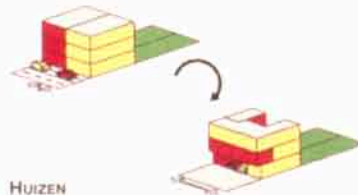
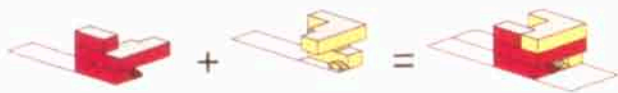

HUIZEN

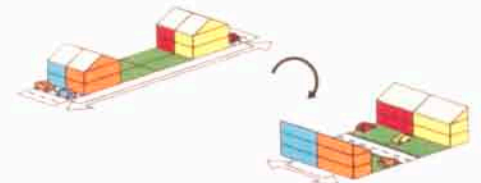

IJSSELSTEIN

Diferentes estudios volumétricos/tipológicos para viviendas
 Different volumetric/typological studies for dwellings

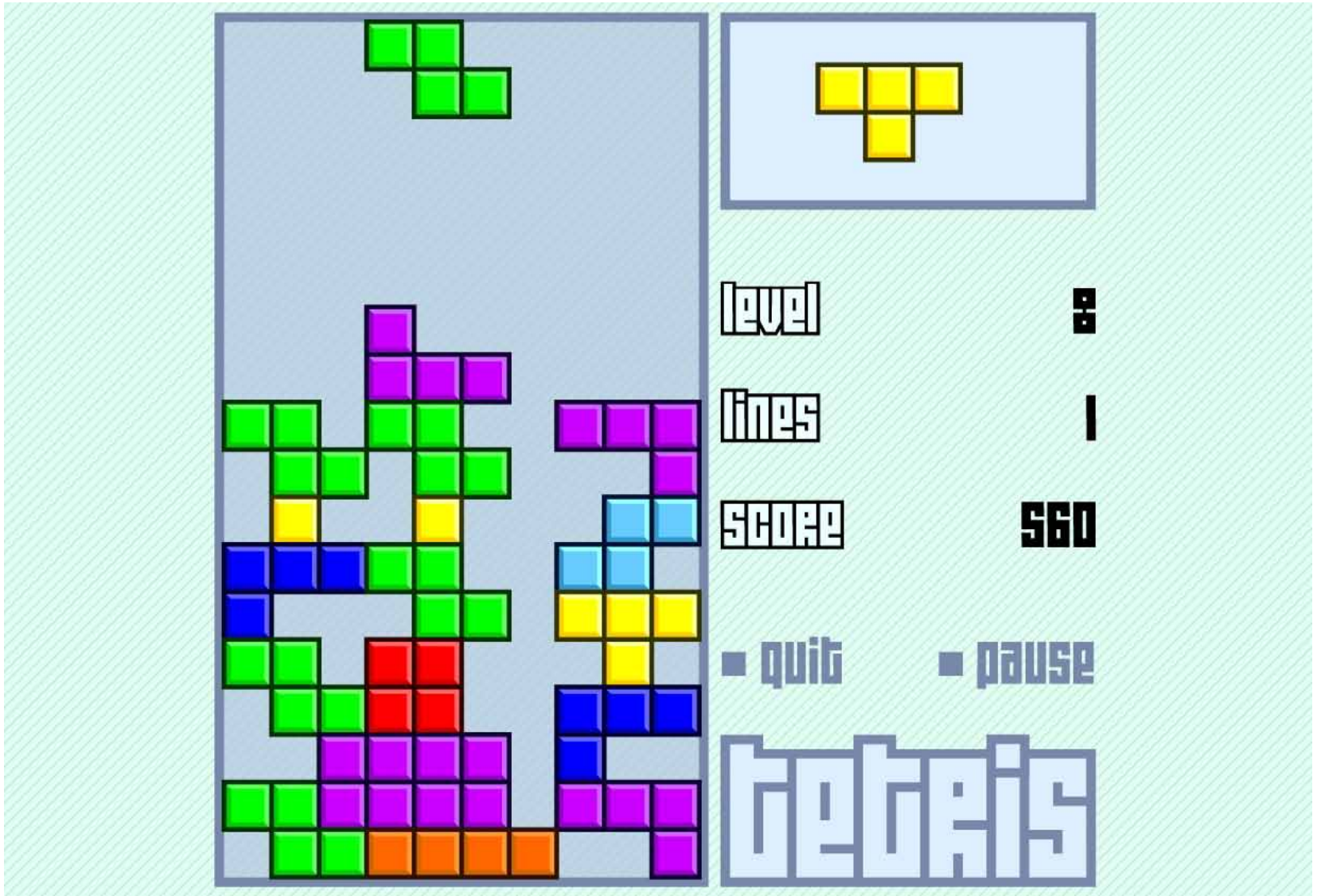

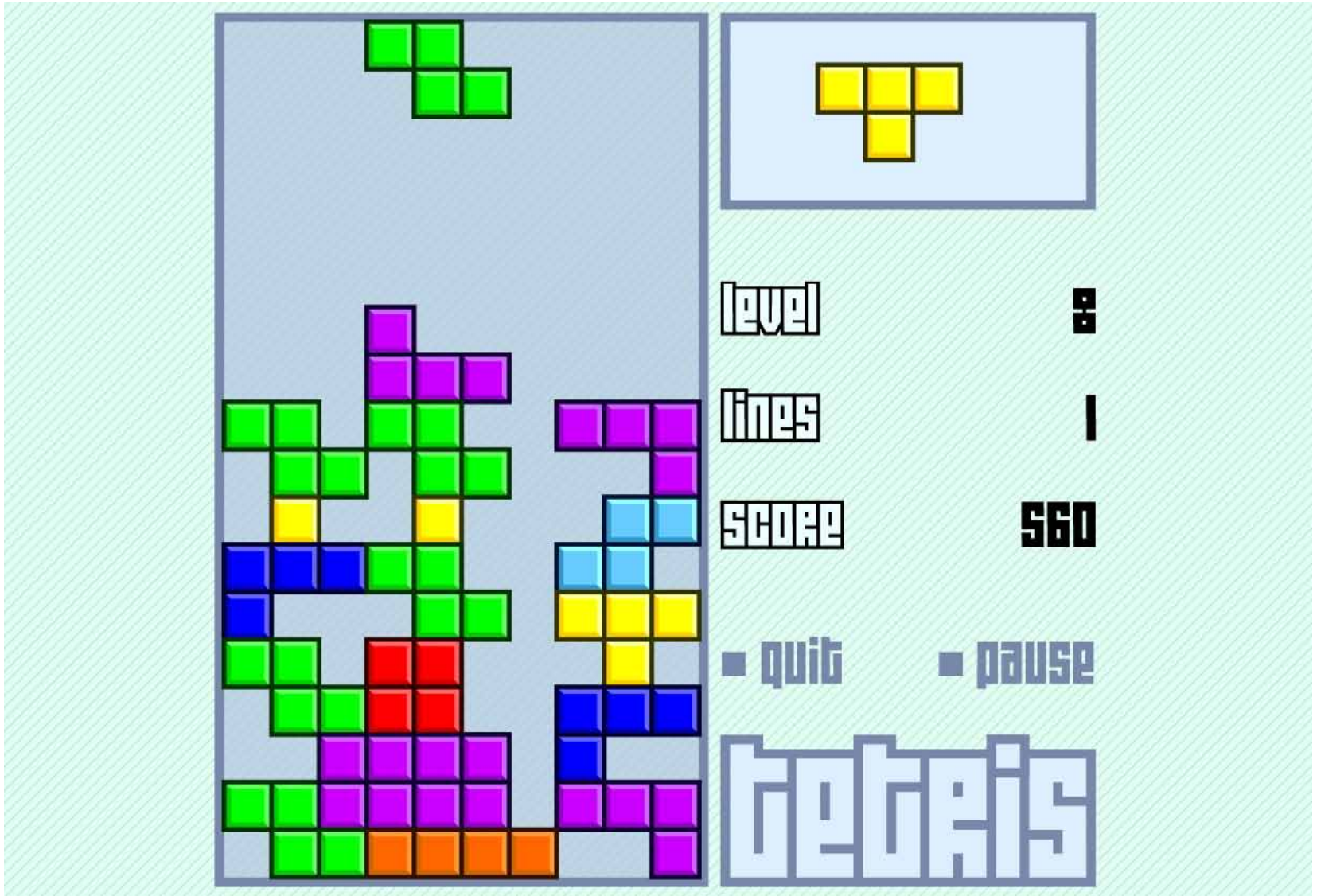

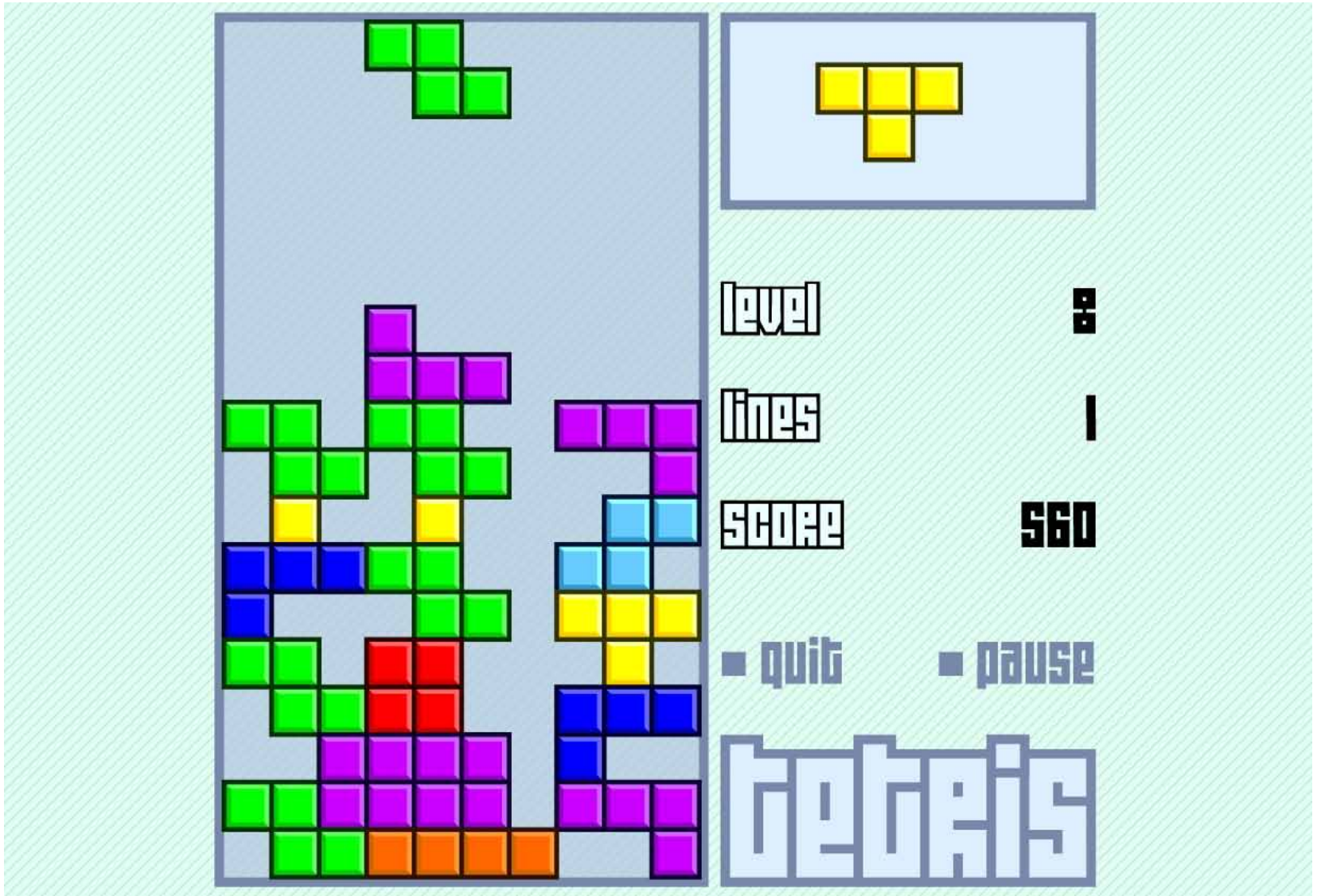

Discussions

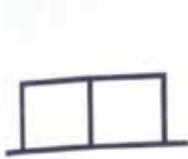

161094
2 Storeys 14 deep



231194
4 Storeys 7 metres deep
No wide views to park

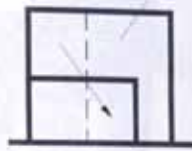

141294
House in a house
No roof access house 1
Small garden access house 2



231295
Alternating floors 1
No roof access house 1

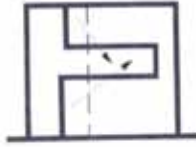

040194
Alternating floors 2
Too little garden access for house 1

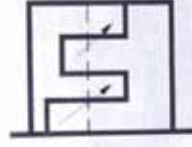

120195
Alternating floors 3
Too little garden access for house 1

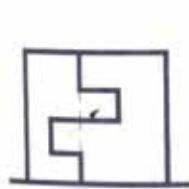

200295
Alternating floors 4
Wider garden access + roof access



090395
Outdoor space
Roof terrace house 1
Garage + roof terrace house 2

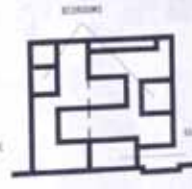

130495
Final result
Bedrooms in 1 + 2
Plausible house 2
pass. fire regulations



MVRDV

Discussions



161094
2 Storeys 14 deep



231194
4 Storeys 7 metres deep
No wide views to park

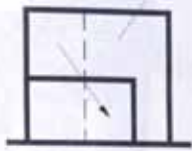

141294
House in a house
No roof access house 1
Small garden access house 2



231295
Alternating floors 1
No roof access house 1

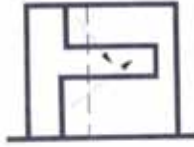

040194
Alternating floors 2
Too little garden access for house 1

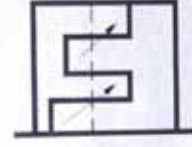

120195
Alternating floors 3
Too little garden access for house 1

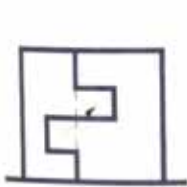

200295
Alternating floors 4
No roof garden access + roof access



090395
Outdoor space
Roof terrace house 1
Garage + roof terrace house 2

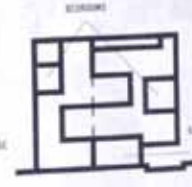

130495
Final result
Bedrooms in 1 + 2
Plausible house 2
but, for regulations



**RECYCLING
TYPOLOGIES
+ CONCEPTS**

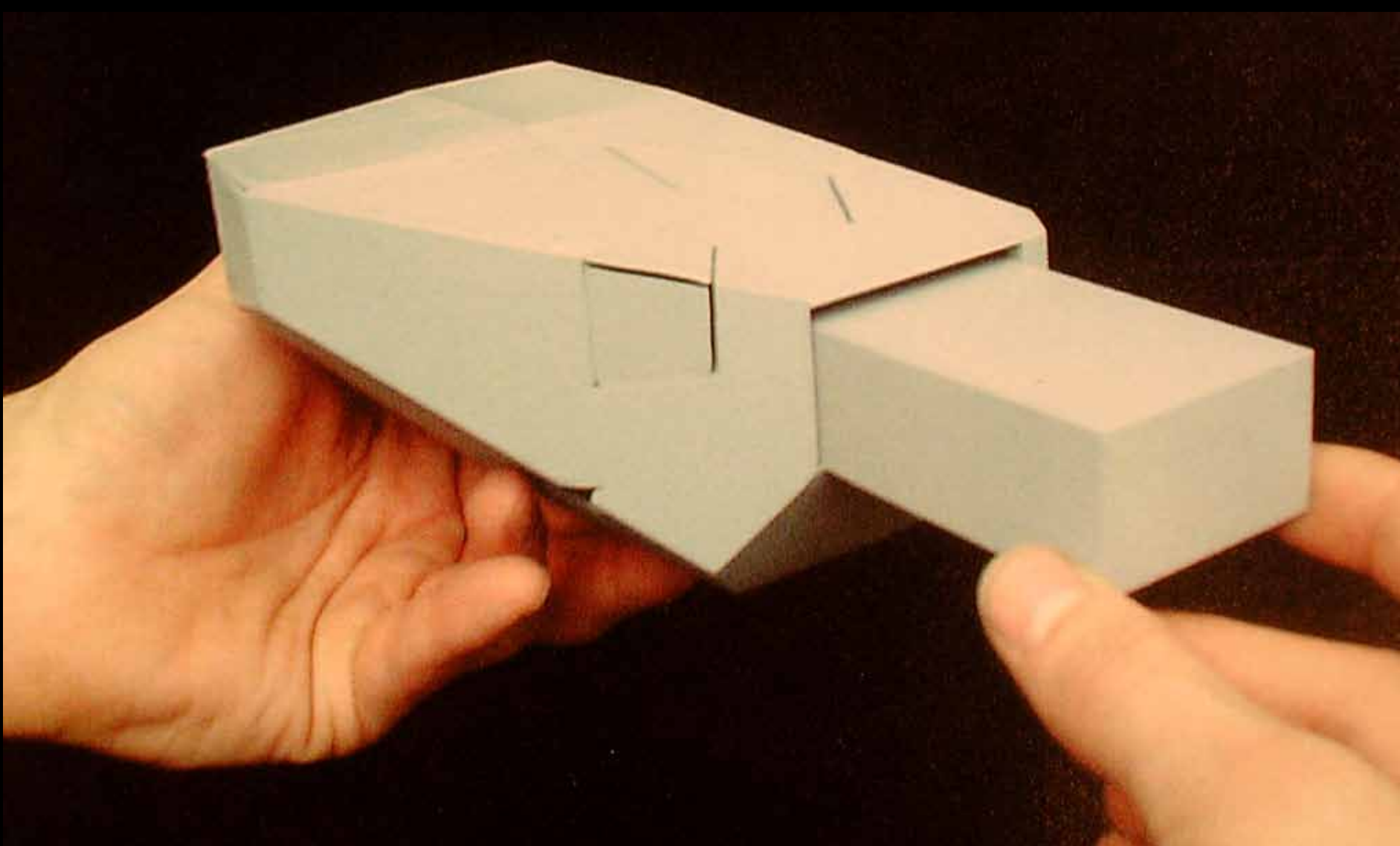

REM KOOLHAAS

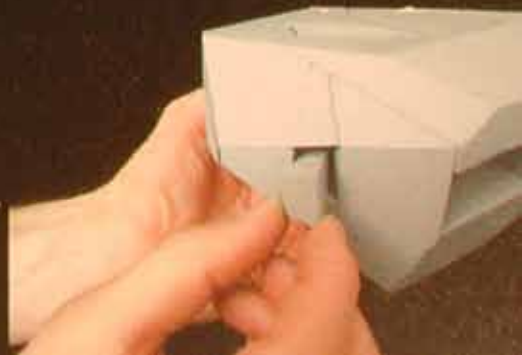
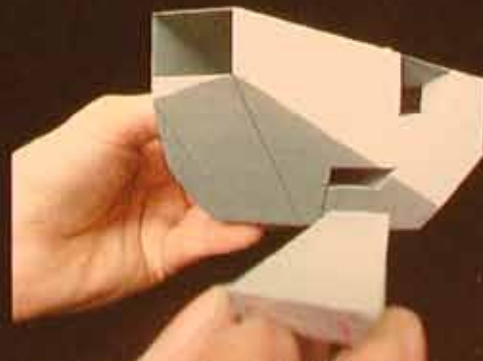
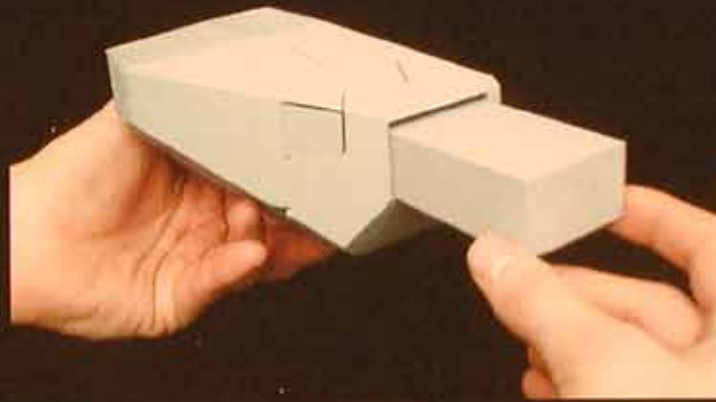
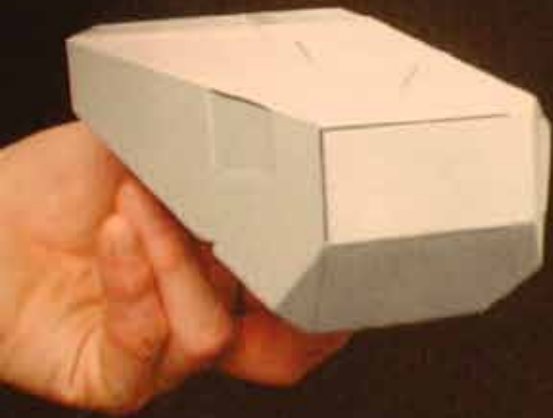

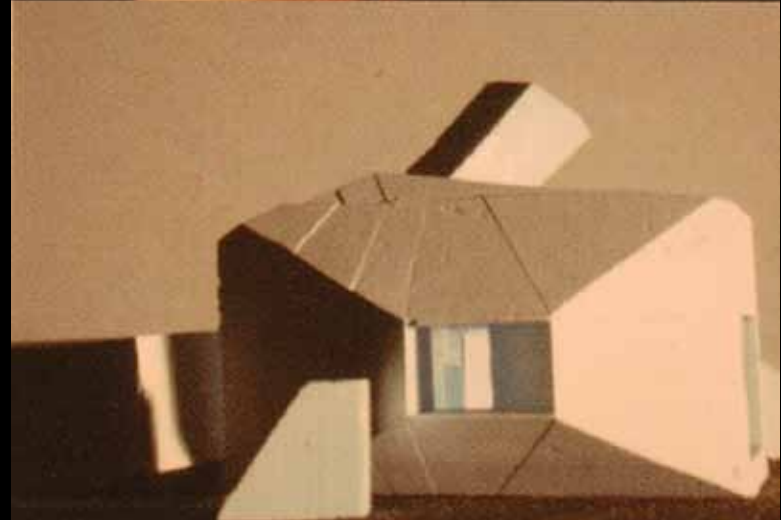
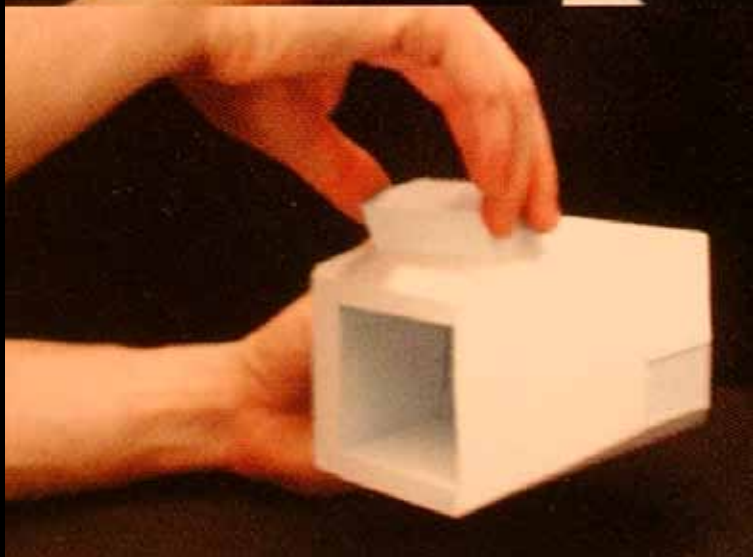
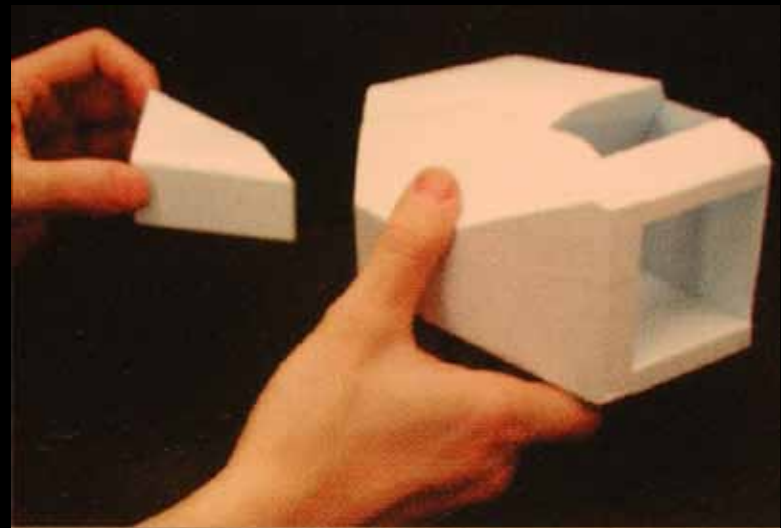
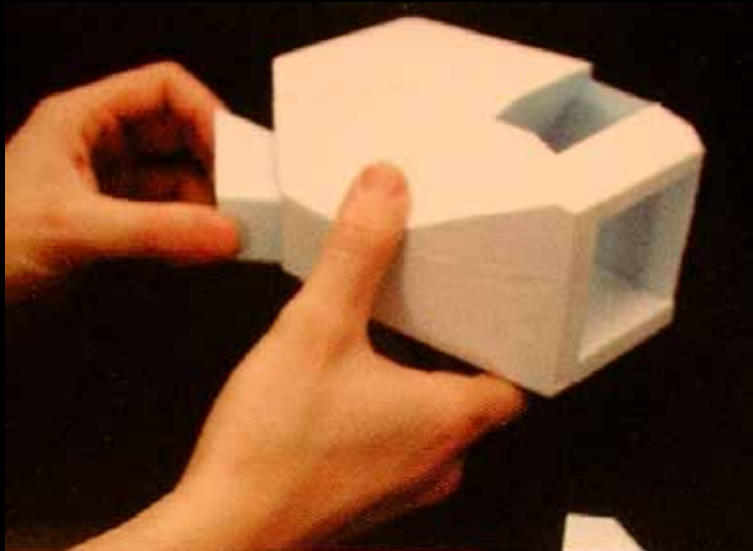

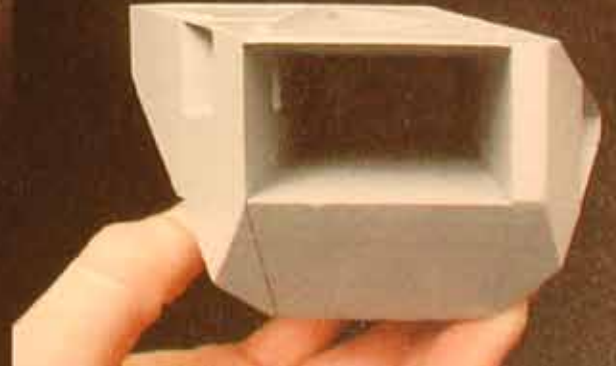
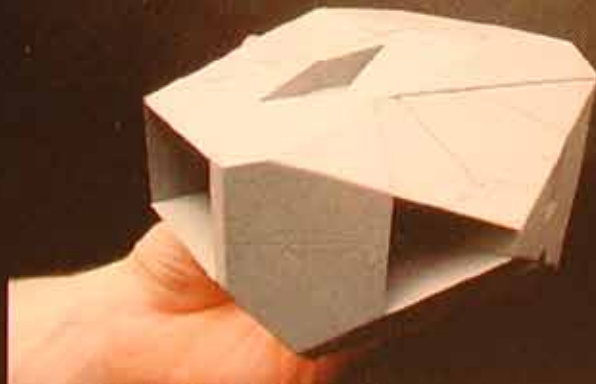
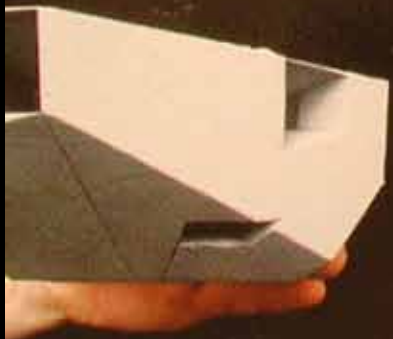
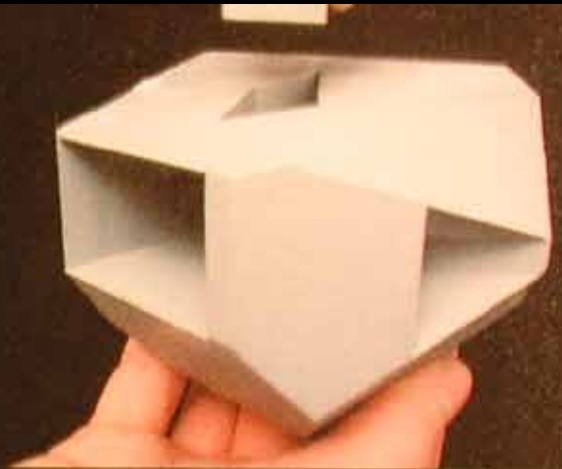
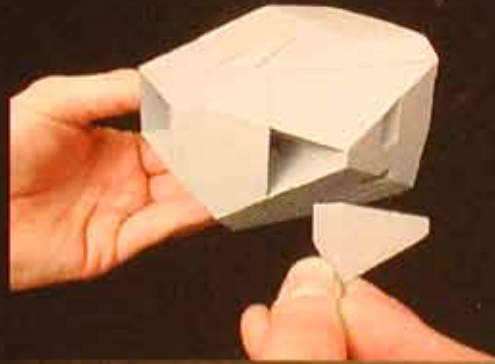
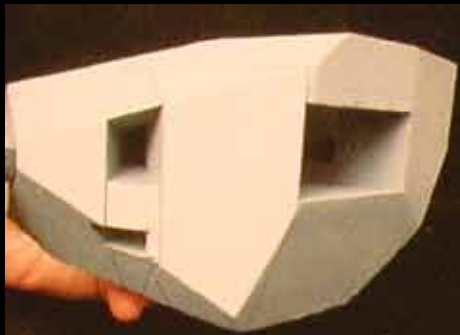



Y2K HOUSE



Y2K HOUSE

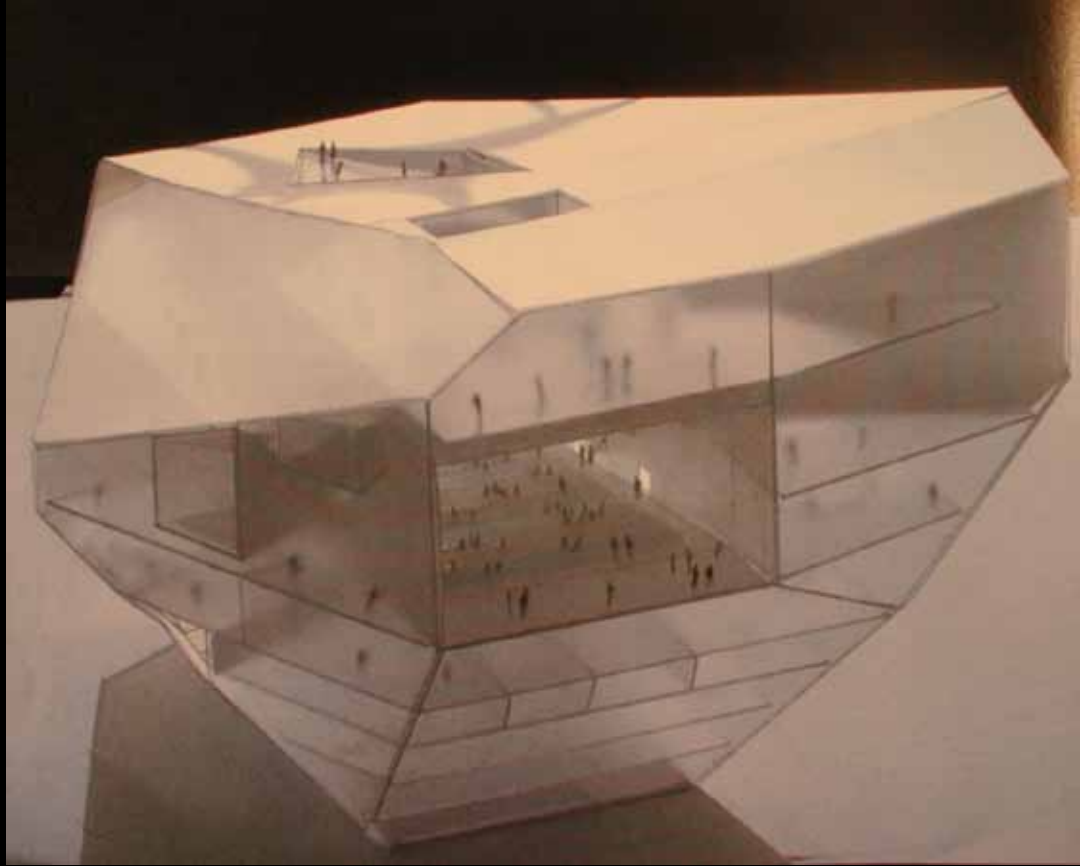

CASA MUSICA

WWW.OMA.EU

RECYCLING

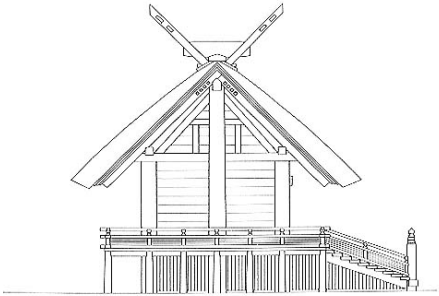
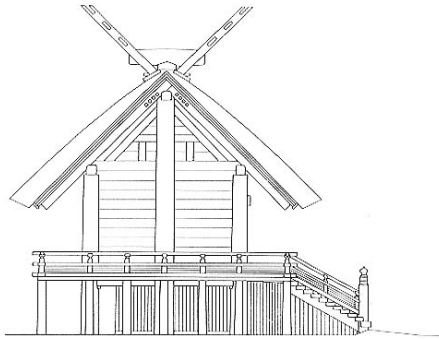

ISE SHRINE



GREEN & GREEN



PIER LUIGI NERVI

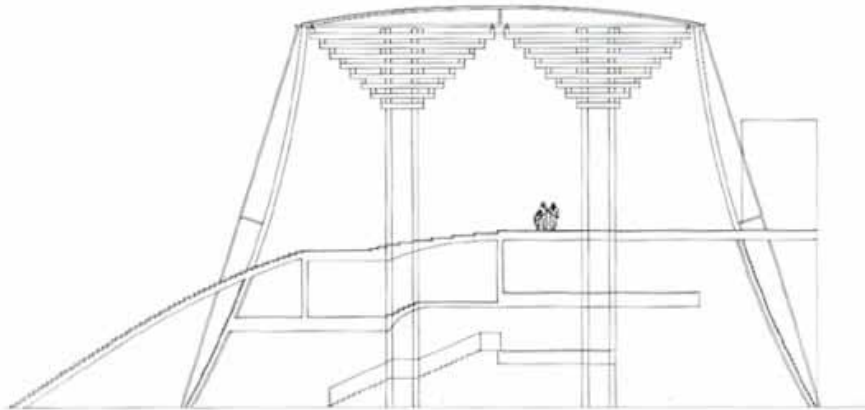
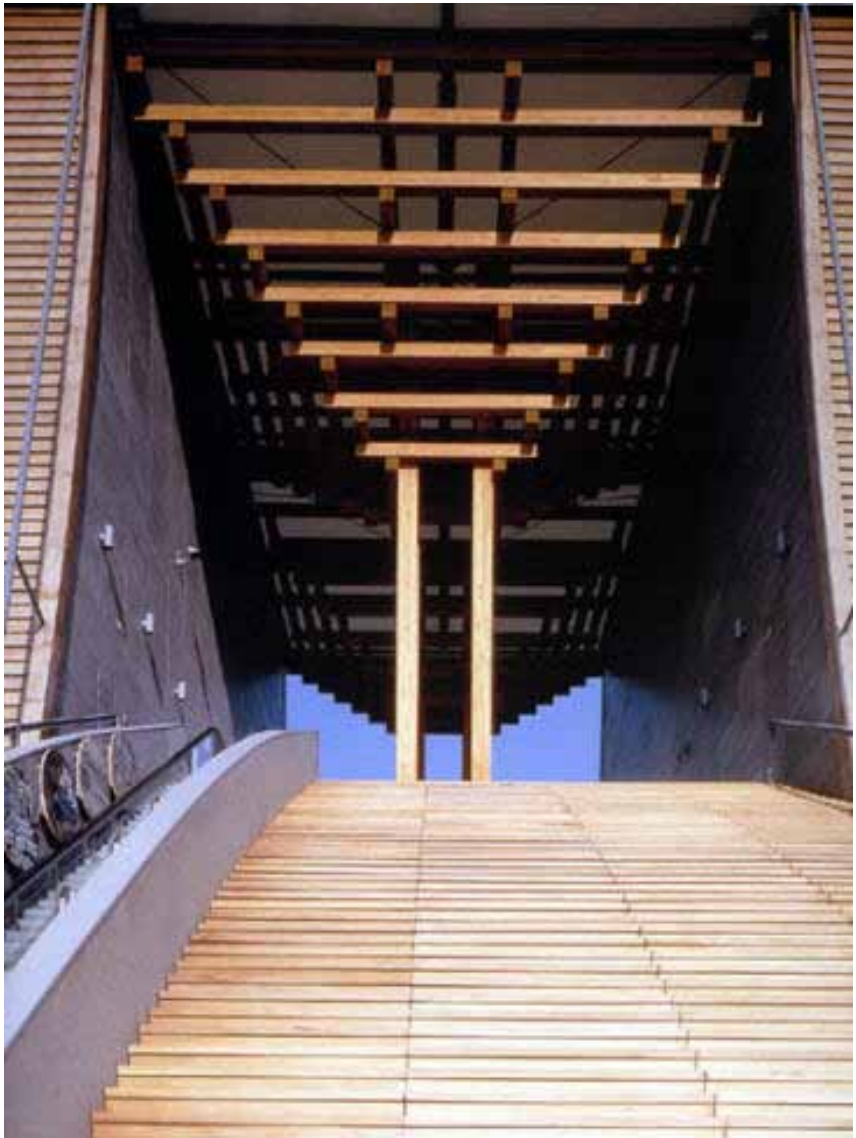

TADAO ANDO

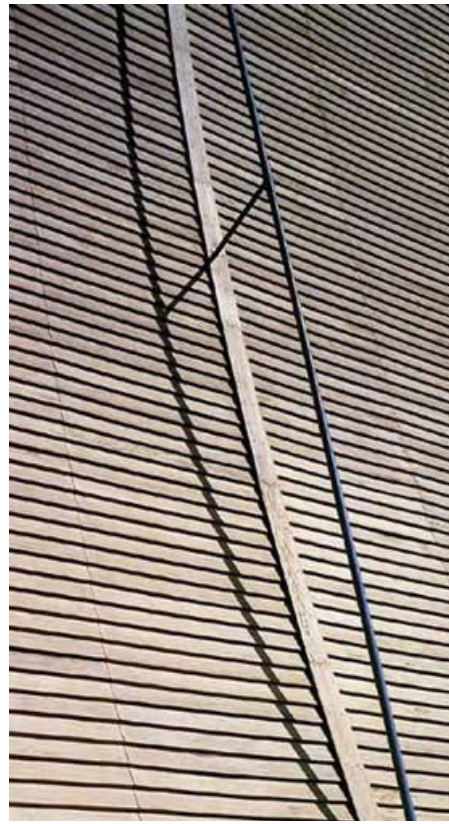

TADAO ANDO

**RACHAEL
WHITEREAD
MEMORY**

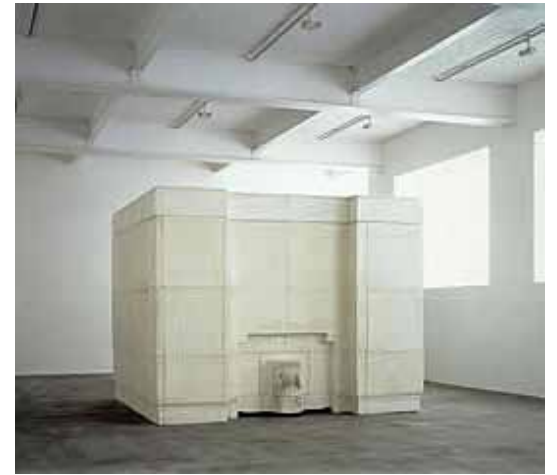
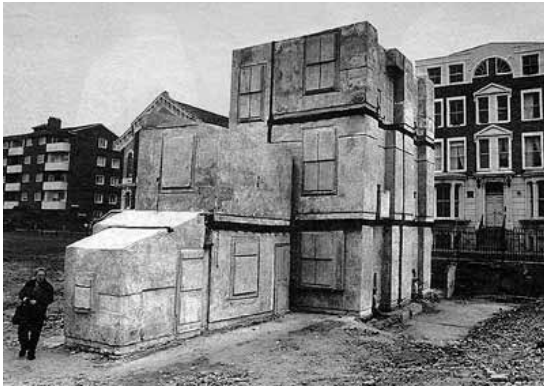



Rachel Whiteread "Sin Título (Doméstica)"

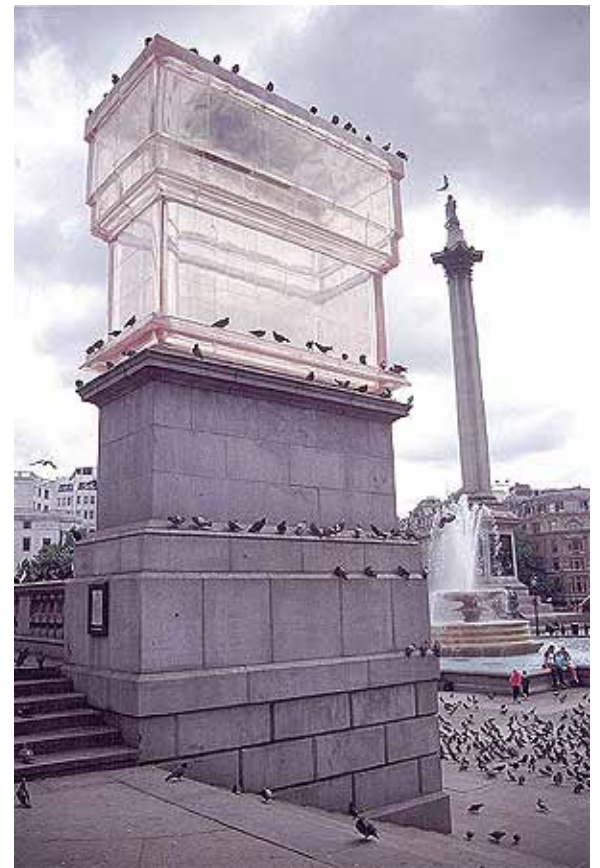









PETER EISENMAN

RICHARD SERA

MEMORY



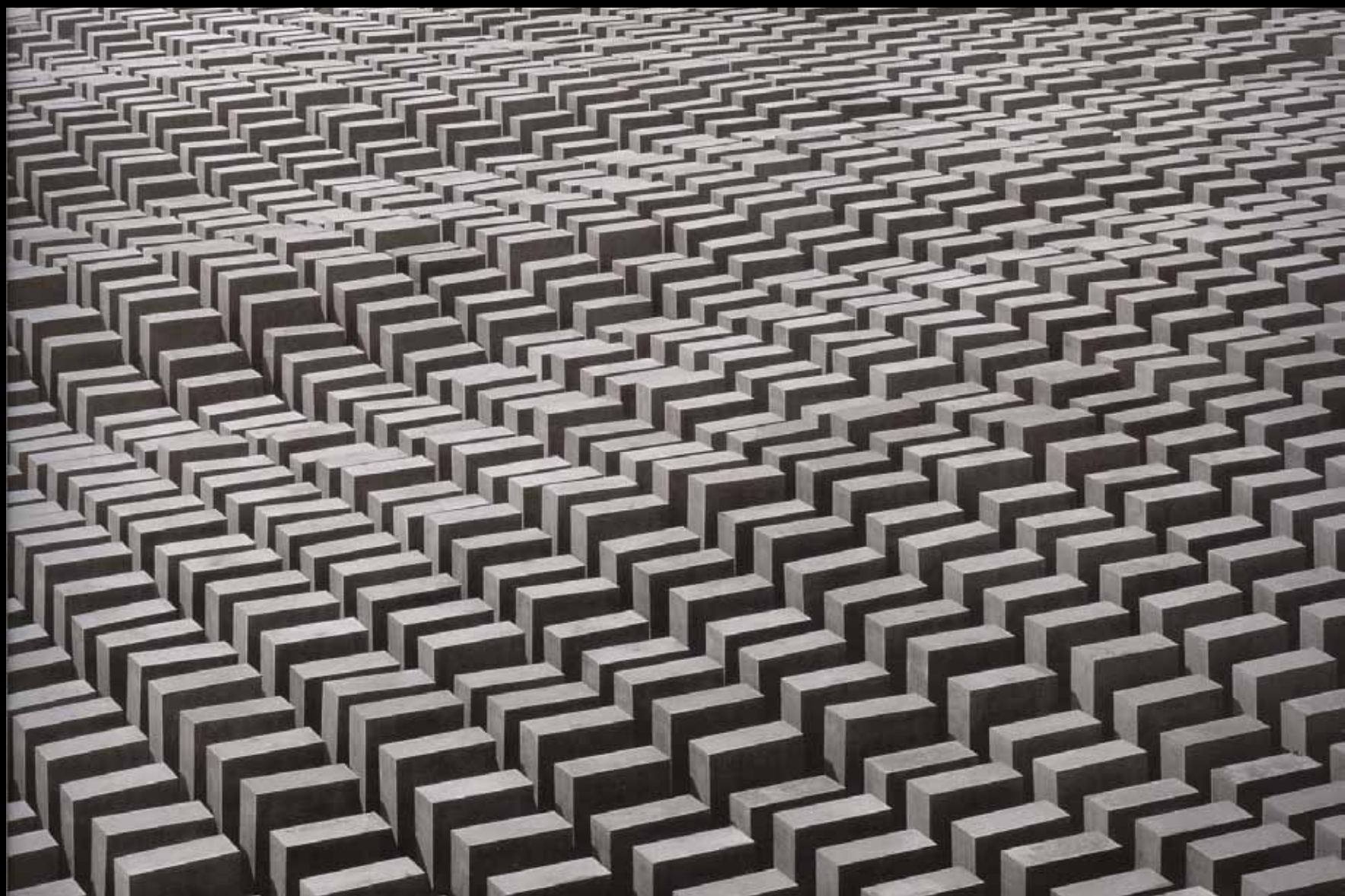



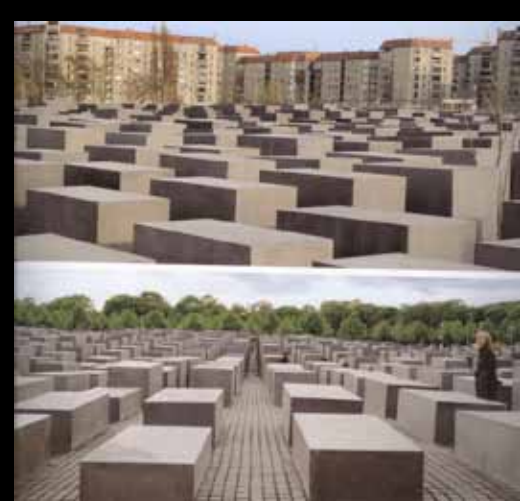

NOX-ART-ARCHITECTURE.COM

ZAHA-HADID.COM

F-O-A.NET

TED.COM

STUDENT WORK

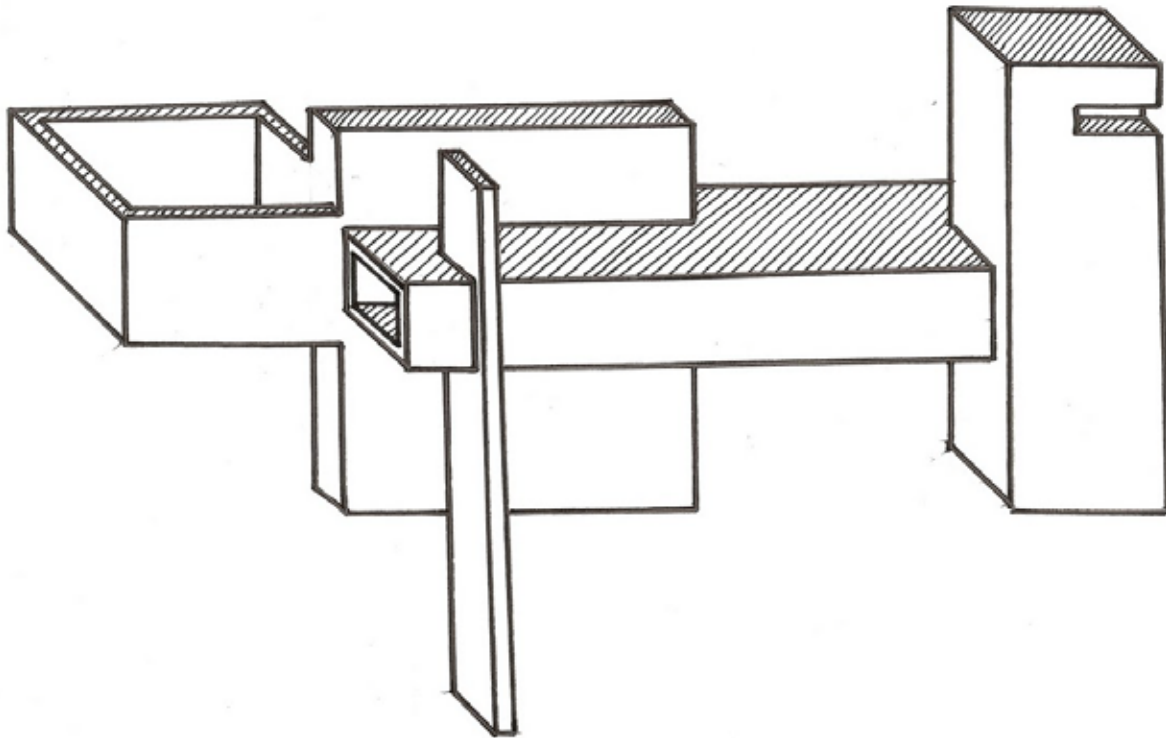

JAMES GITO

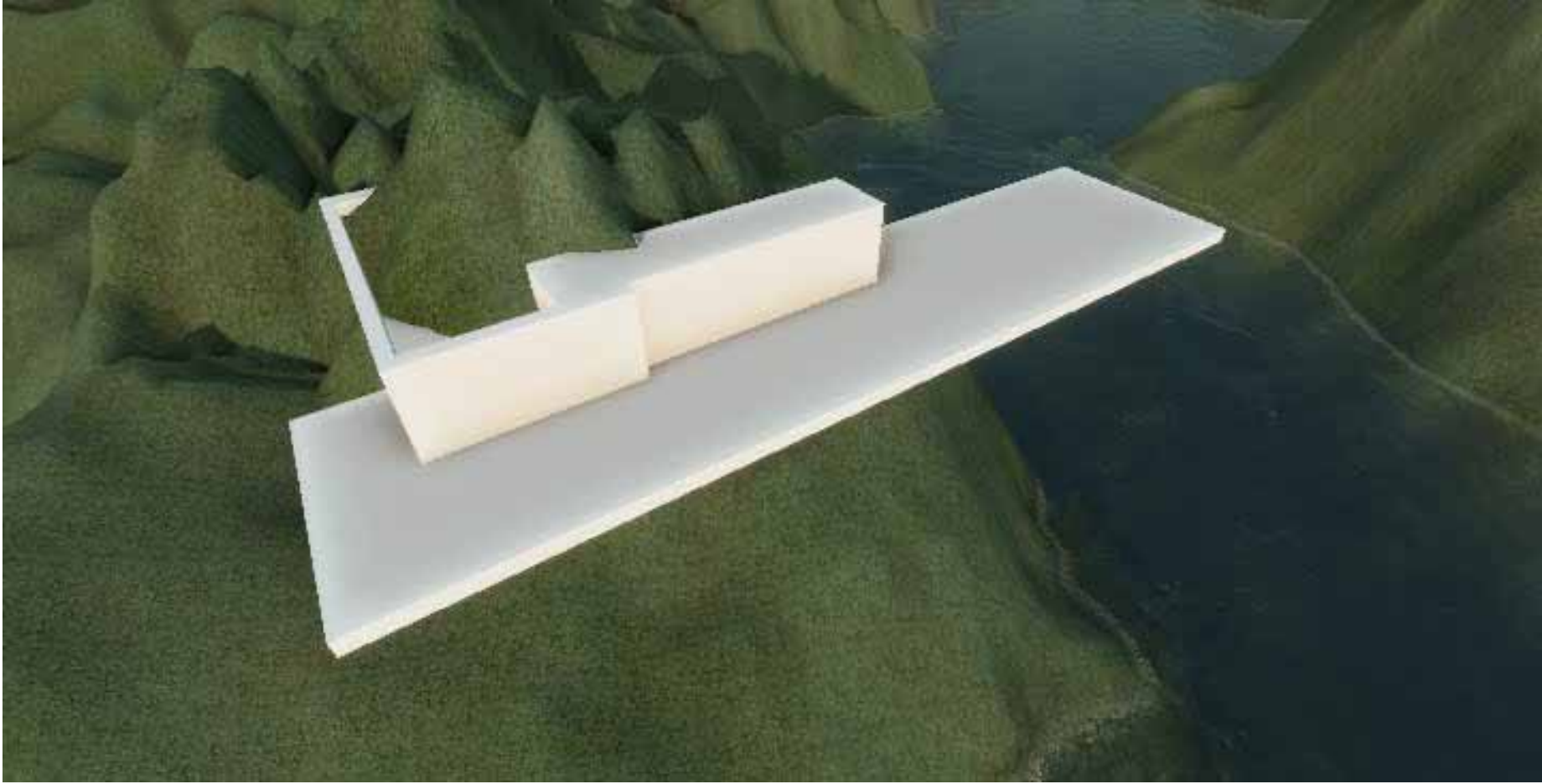

JAMES GITO



JAMES GITO

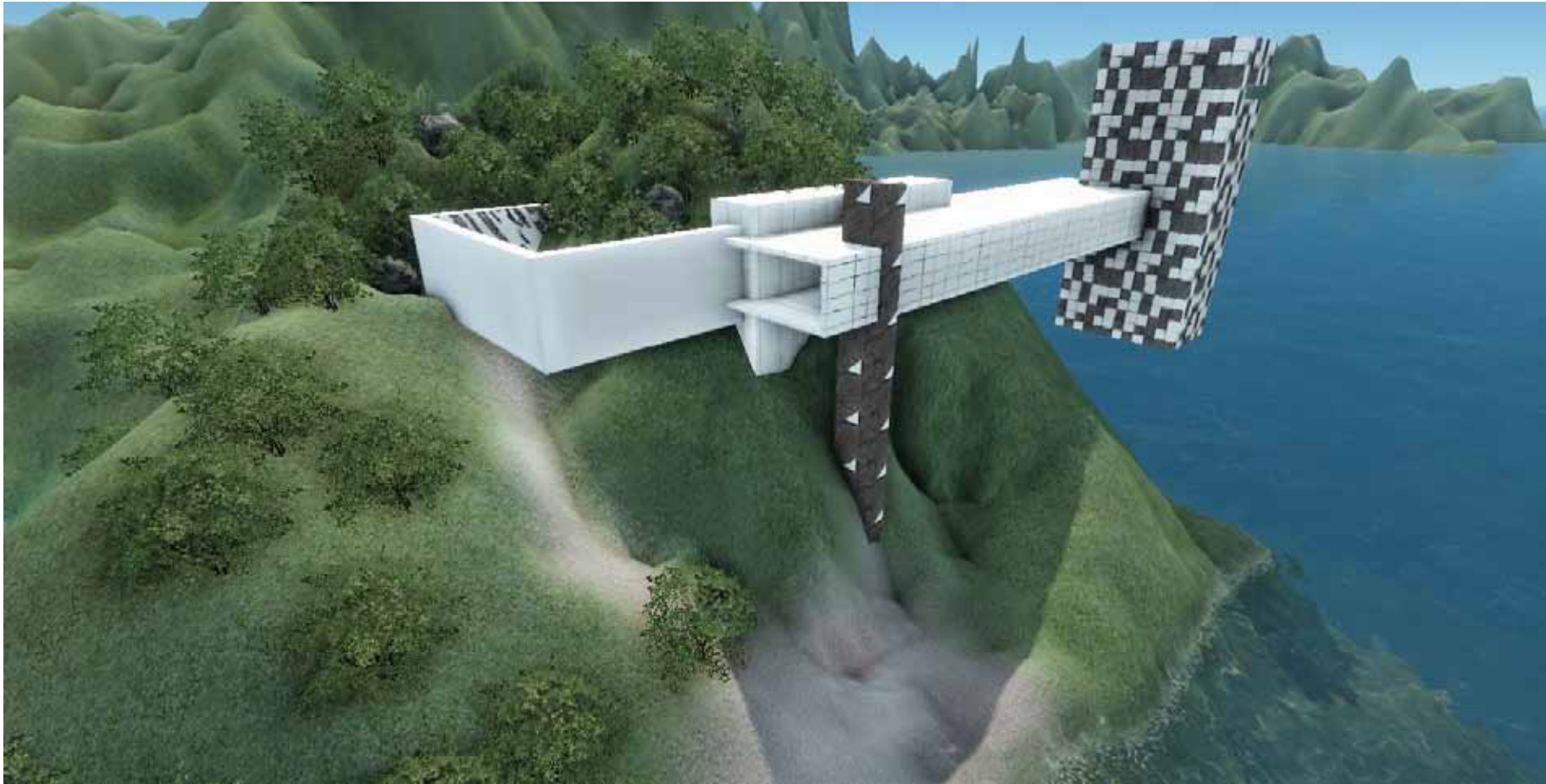

JAMES GITO



JAMES GITO



JAMES GITO

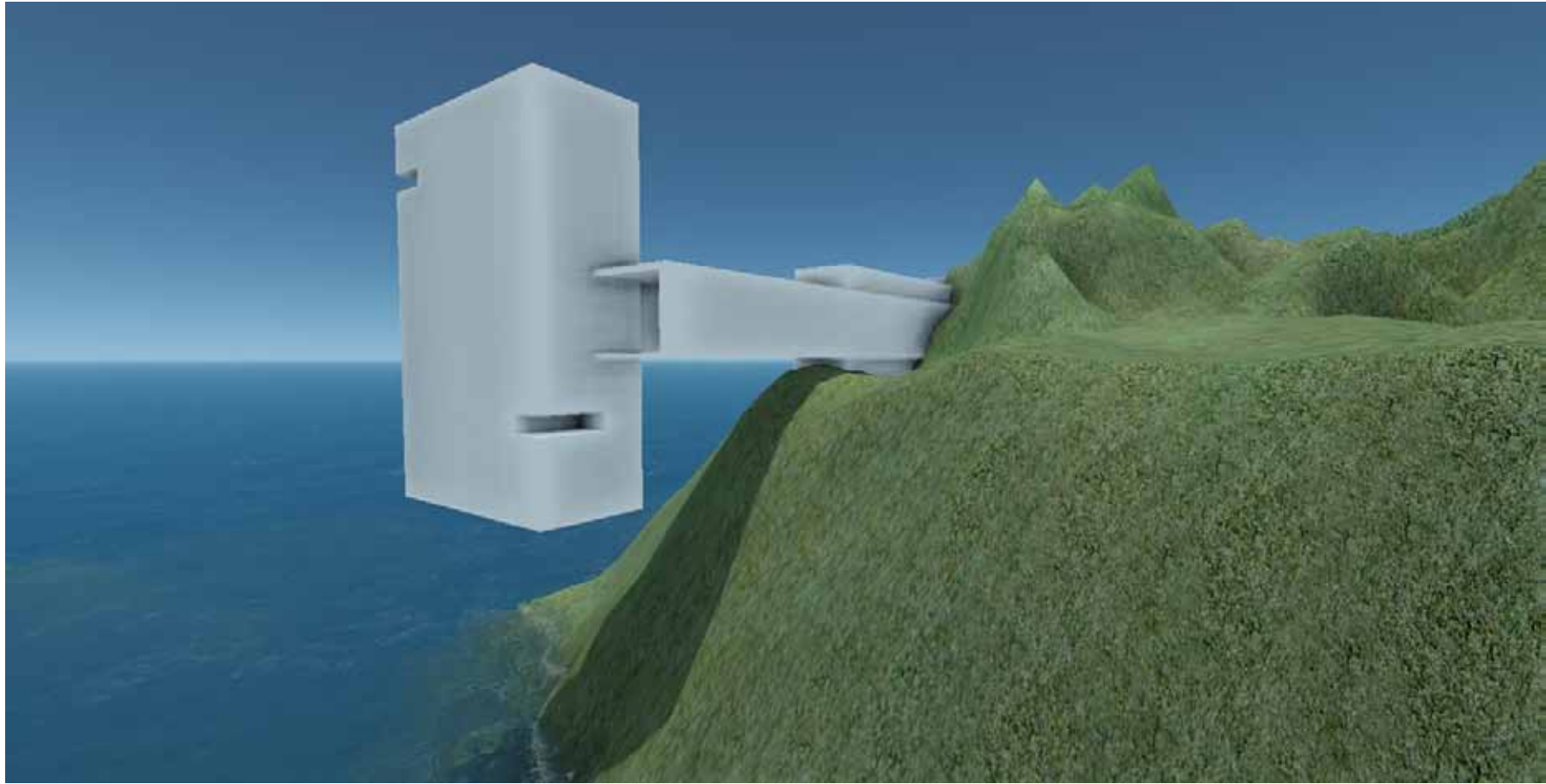

JAMES GITO

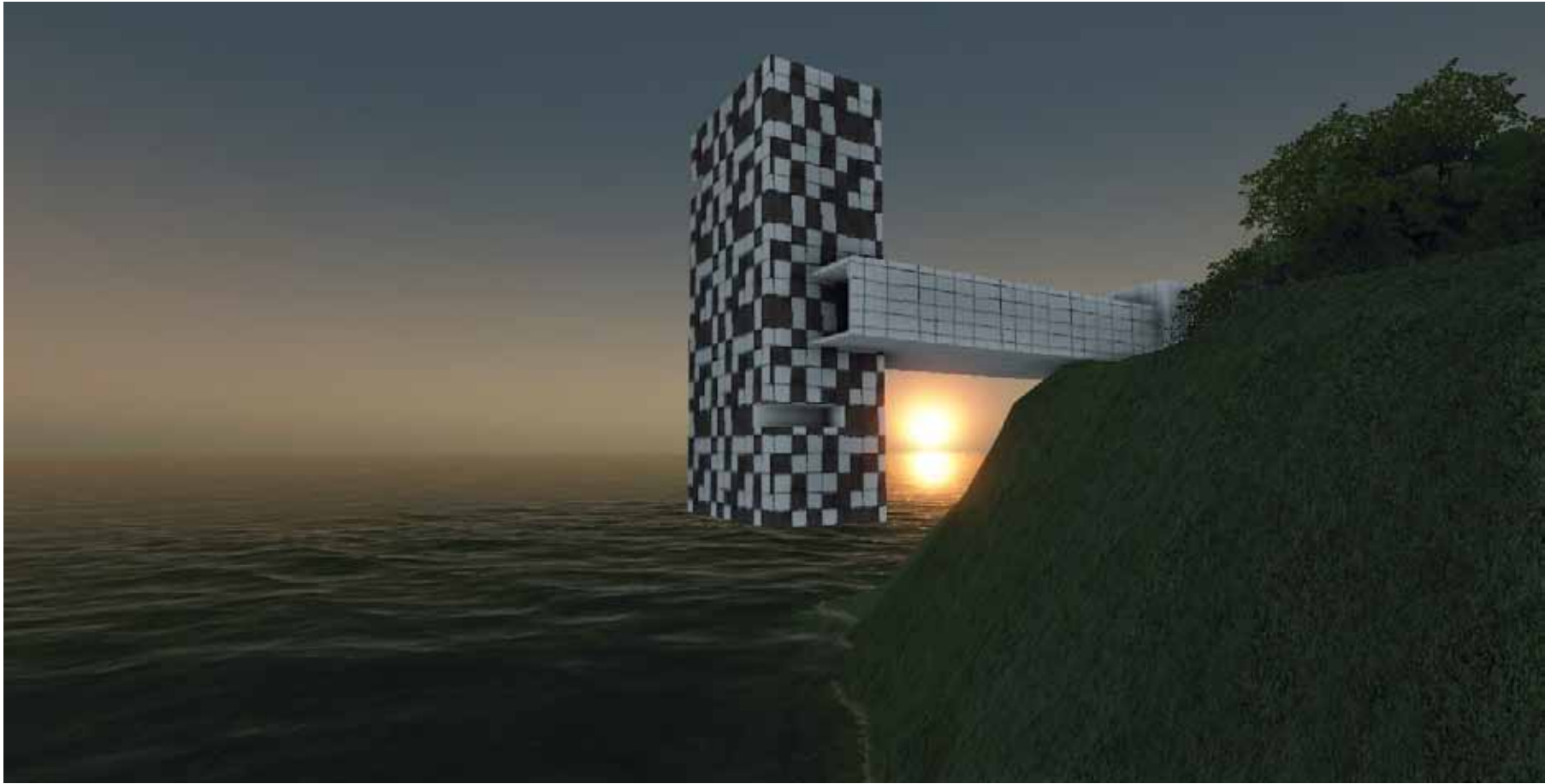

JAMES GITO

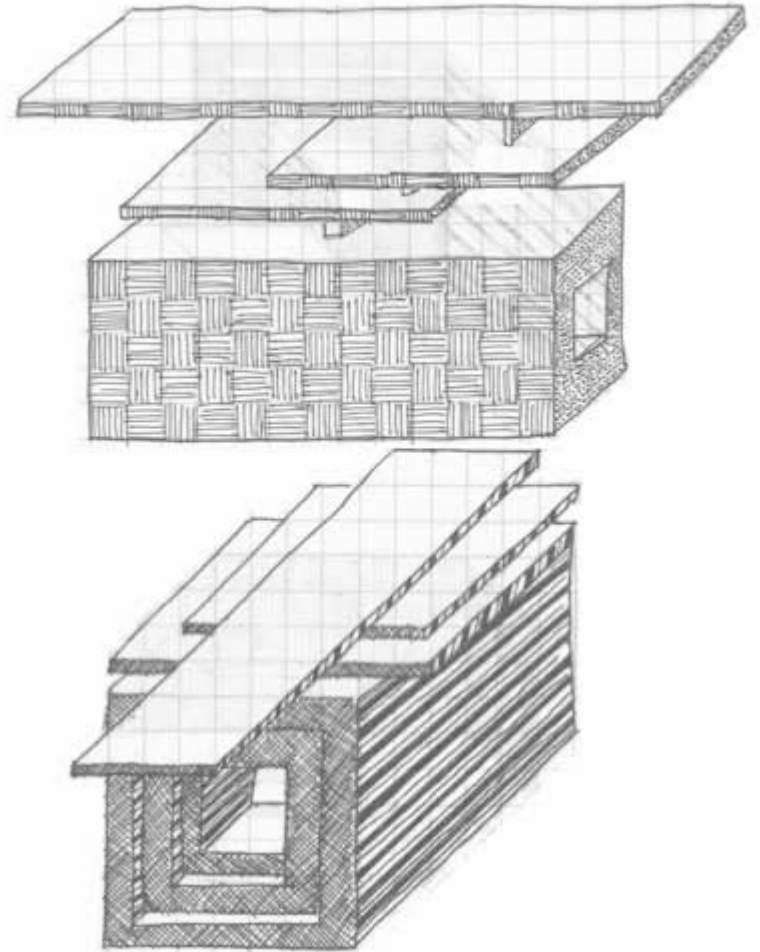
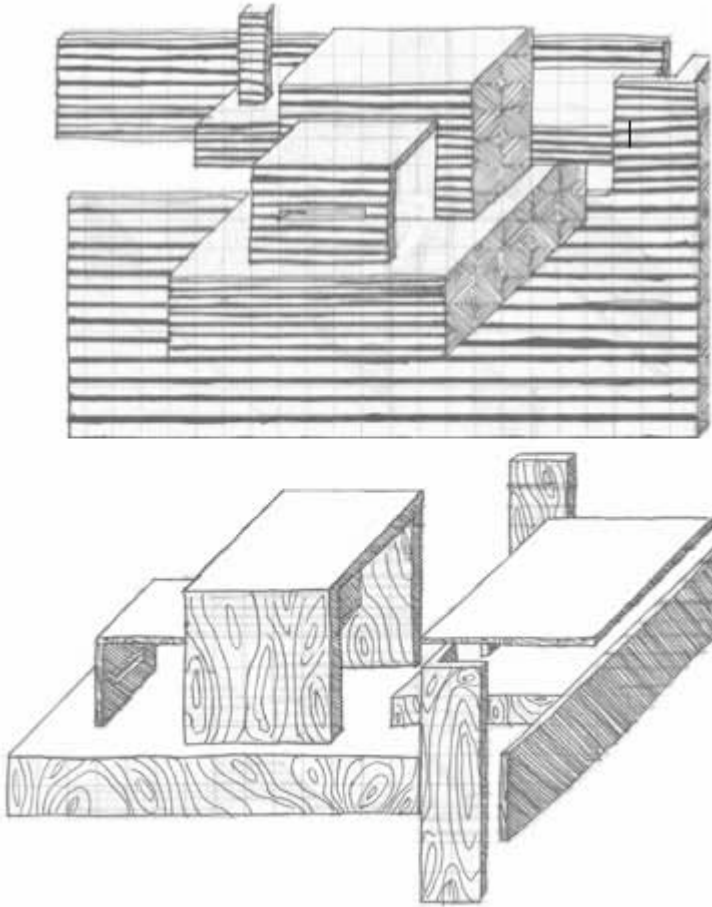

OLIVIA GREEN



OLIVIA GREEN



OLIVIA GREEN

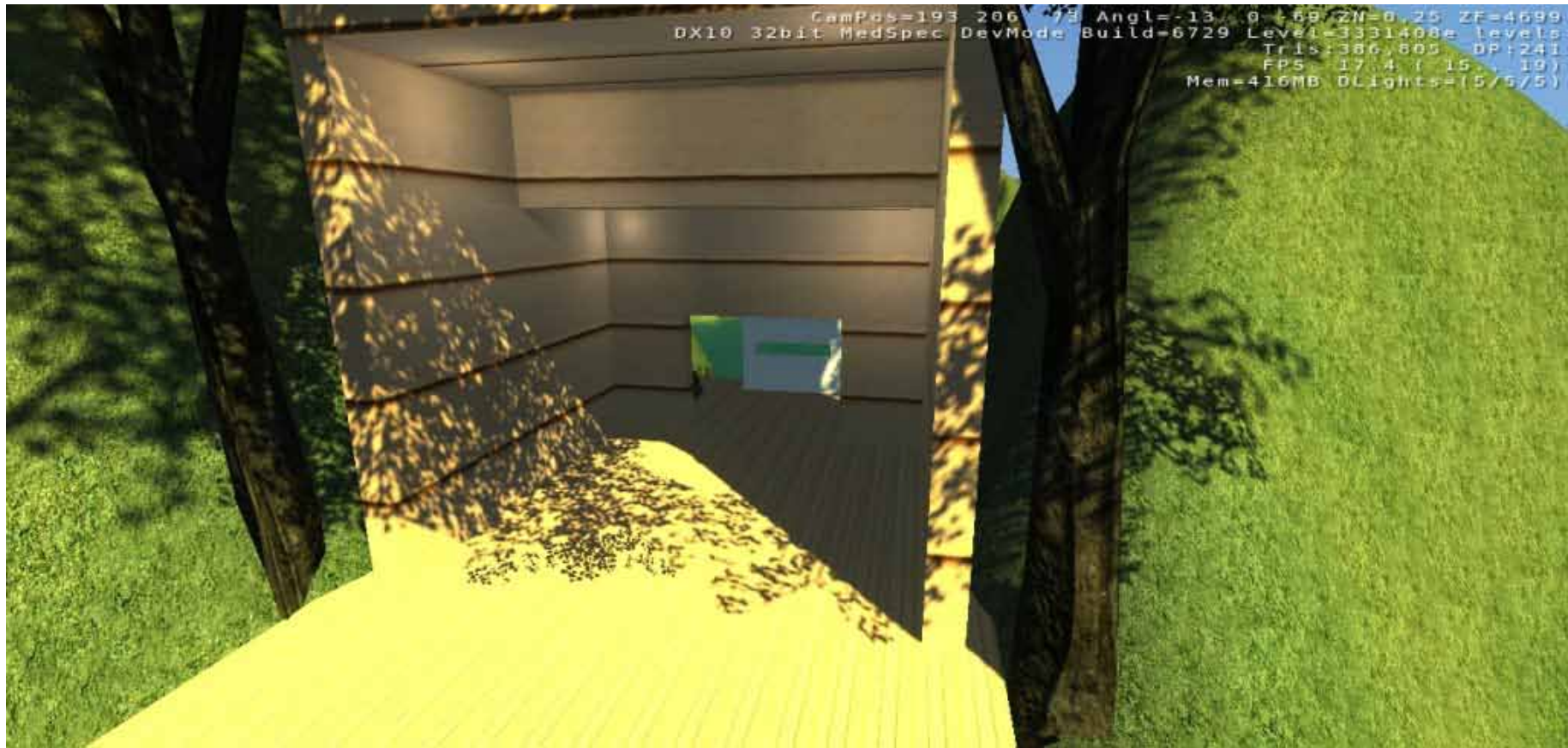

OLIVIA GREEN



DEMAS RUSLI

ARCH 1101 EXP2 2010 designed by Ricky Fan

The moodboard of the concept

The inspiration of the architecture form

Life
Time
Nature
Insight
Wisdom
Innovative
Resolution

No-Boundary
Invisible Form
Undefine
Wisdom
Twist

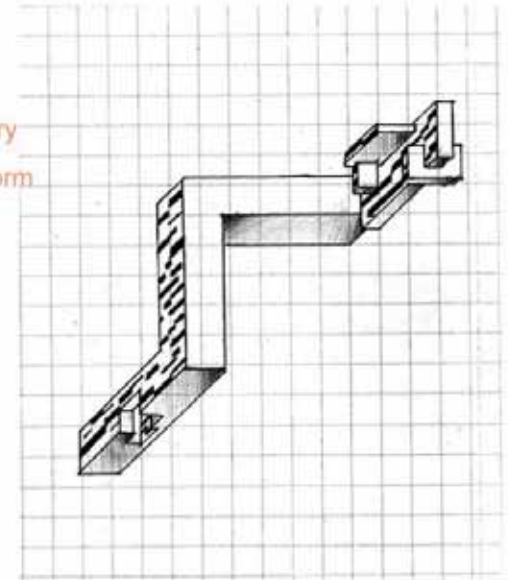

The draft sketches of the idea

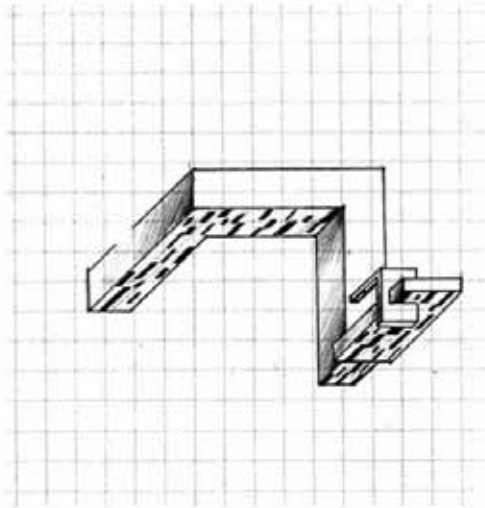

Branch
Wisdom
Intersection
Life
Relationship
Evolution
Adaptive

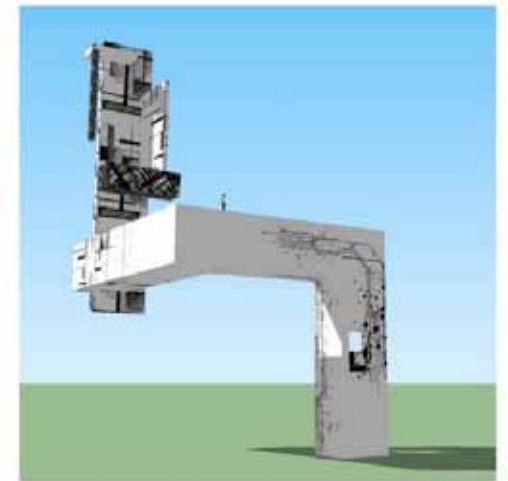

RICKY FAN

ARCH 1101 EXP2 2010 designed by Ricky Fan
The moodboard of the concept

The inspiration of the architecture form

I take effort to create
the architecture combining
gradually with the environment

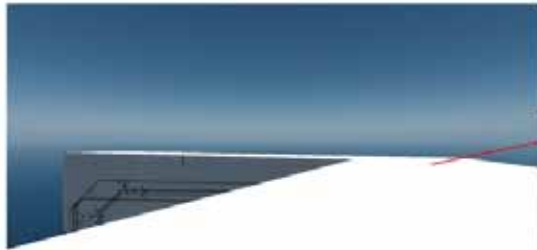

Meeting place:

For the aim of exchanging ideas, I create a space which is the fusion of the sky and earth; the mergence of the horizon and ground surface.

(The space seems to become 'no boundary')



S.H.'s Lab:

The idea of this space is 'undefine space', in general, the space is comprised from dot to line, from line to surface. But according to S.H.'s 'no boundary' idea, I make a bold assumption and create an experience of 'imaginative space'.

The pattern is supporting this idea

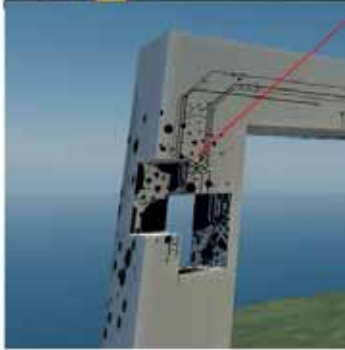

C.D.'s Lab:

'Evolution' is C.D.'s great attainment. The key value of this space are 'intersection', 'chain', 'growth' and 'unlimited'.



RICKY FAN

The moodboard of the concept

Stephen Hawking's space

Universe No-Boundary
Invisible Form
Life Empty Love
Peace Time Strong Nature
Undefined horizon
Wisdom
Twist

"...But if the universe is really completely self-contained, having no boundary or edge, it would have neither beginning nor end: it would simply be. What place, then, for a creator?"

The intersection of their ideas

Branch Growth
Natural Selection Wisdom
Time Human
Weak
Intersection Life Evolution Strong Relationship
Nature

Charles Darwin's space

"...under the complex and sometimes varying conditions of life, will have a better chance of surviving, and thus be naturally selected."



RICKY FAN



PATRICK LEAL

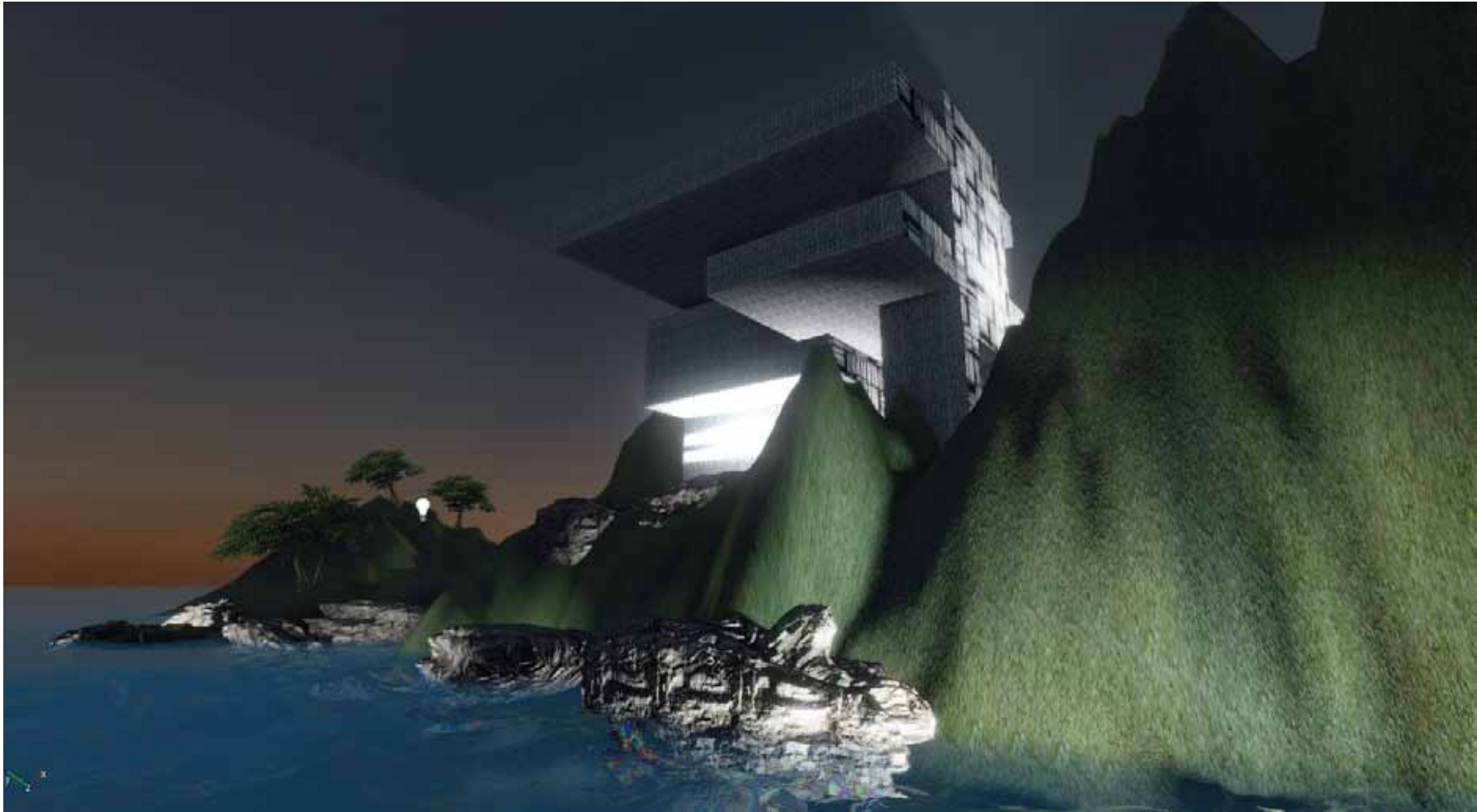

PATRICK LEAL

CamPos= 57 131 23 Angl=-30 0 -45 ZN=0.25 ZF=4527
DX10 64bit MedSpec DevMode Build=6729 Level=light try
Tris:192,361 DP:188
FPS 45.5 (8..152)
Mem=482MB DLights=(0/6/6)

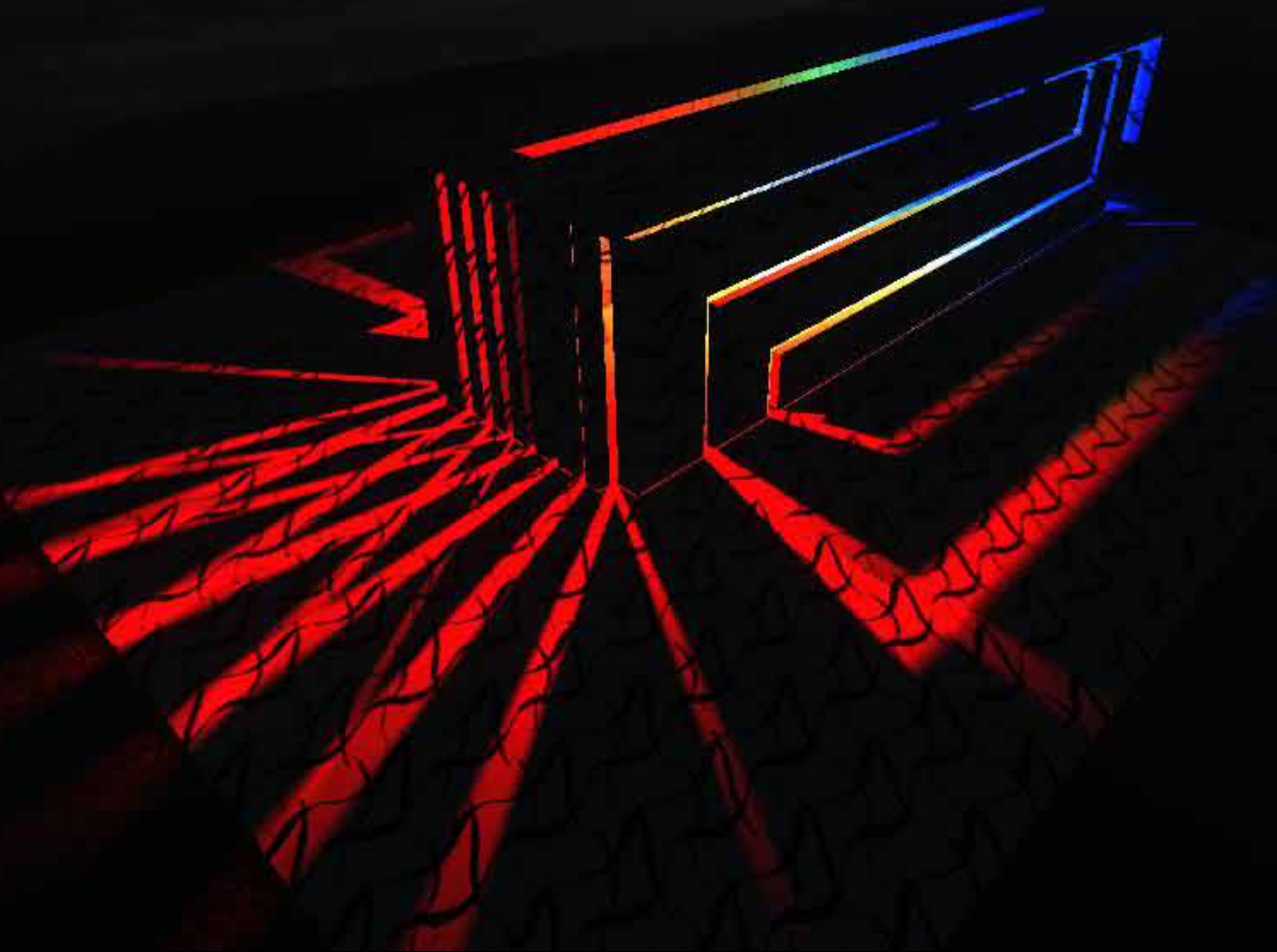

KEVIN SI

CamPos=112 134 29 Angl=-13 0 -33 ZN=0.25 ZF=8000
DX10 64bit VeryHighSpec HDR DevMode Streaming Build=6729 Level=light try
Tris:317,180 DP:703
FPS 32.1 (1.. 64)
Mem=512MB DLights=(29/29/29)



KEVIN SI

XIN ZHANG

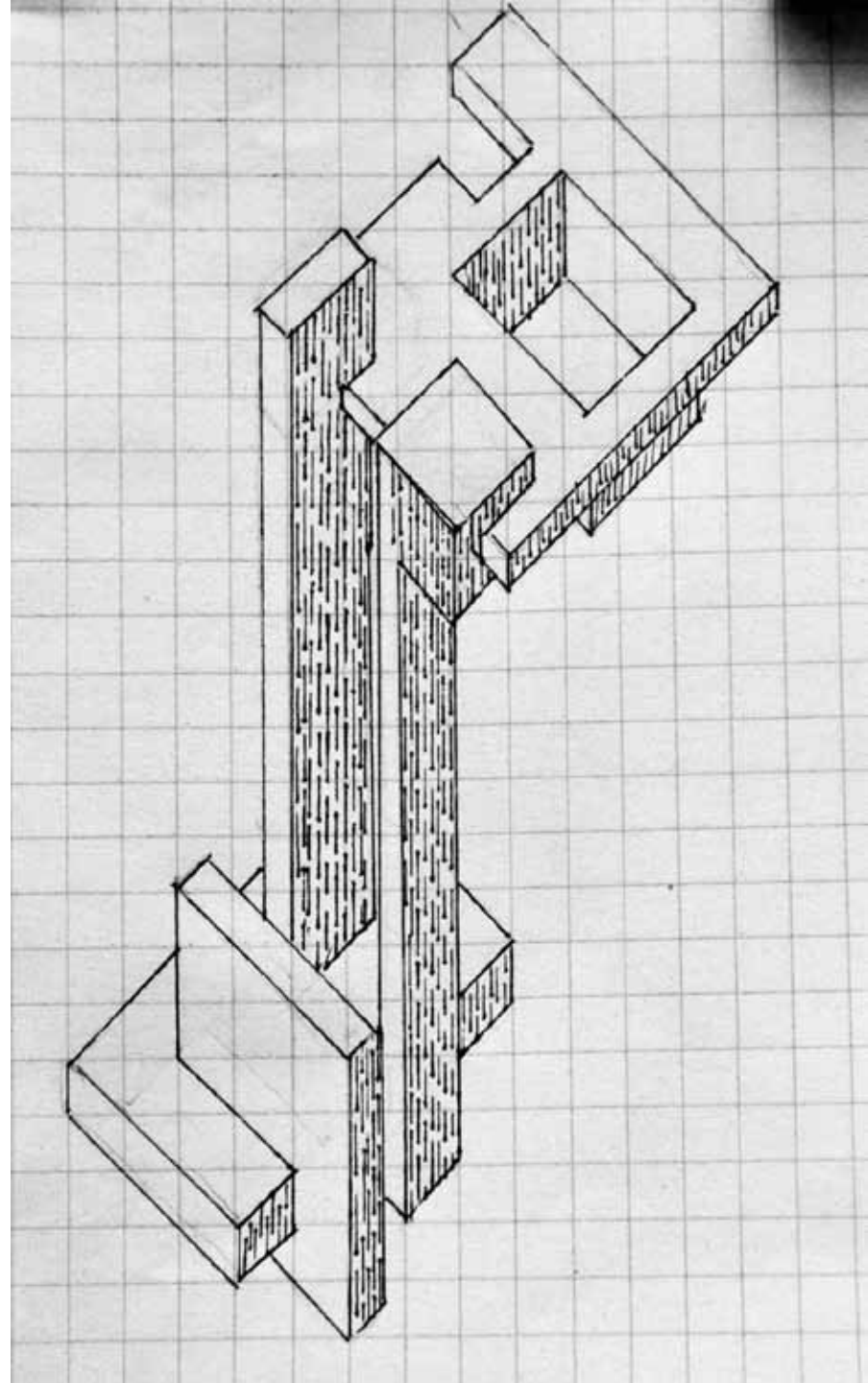



XIN ZHANG

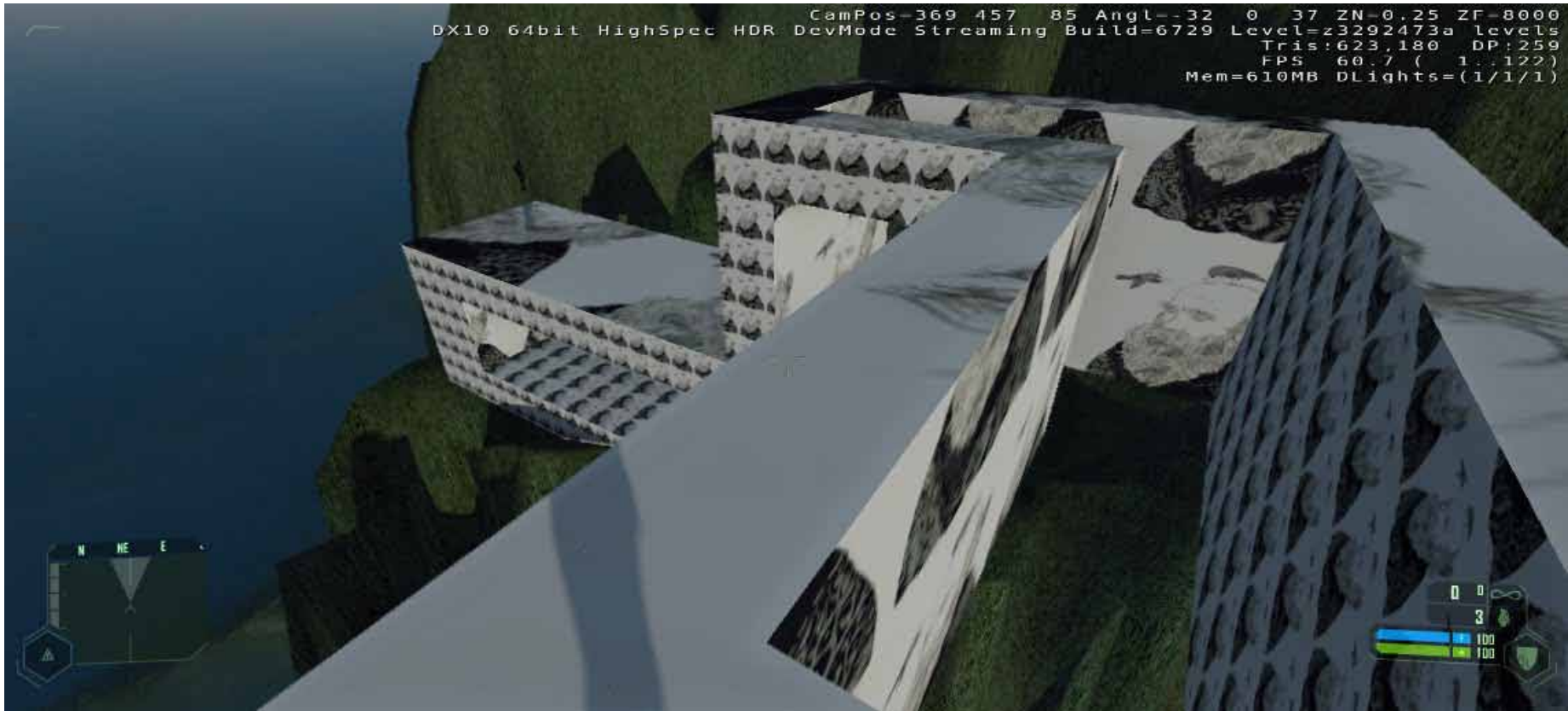

XIN ZHANG



XIN ZHANG

CamPos-244 586 24 Angl- 11 0 -81 ZN-0.25 ZF-8000
DX10 64bit HighSpec HDR DevMode Streaming Build=6729 Level=z3292473c levels
Tris:1222,517 DP:351
FPS 53.7 (50.0 57)
Mem=565MB DLights=(0/32/47)



XIN ZHANG

1. Draw a series of 3 parallel projections exploring the interconnection between pairs of your drawings from week one (make sure that each one of the pair is from a different client). Use carefully hatched lines to highlight one set of surfaces that exist in parallel planes.
2. Draw the same set of 3 parallel projections from the opposite angle.

Note: throughout the class students will be exporting objects from SketchUp to Crisis Wars. To do this, find a student who has a functioning workflow and has a hardware and operating system setup that is the same as you

TODAYS STUDIO

1. Draw a series of 3 parallel projections exploring the interconnection between pairs of your drawings from week one (make sure that each one of the pair is from a different client). Use carefully hatched lines to highlight one set of surfaces that exist in parallel planes.
2. Draw the same set of 3 parallel projections from the opposite angle.

Note: throughout the class students will be exporting objects from SketchUp to Crisis Wars. To do this, find a student who has a functioning workflow and has a hardware and operating system setup that is the same as you

TODAYS STUDIO

UNSW Architecture 2011

SET UP BY JOCK SINCLAIR, THANKS JOCK

FACEBOOK

QUESTIONS?