

THE SPACE BETWEEN

EXP2 INTRO

ELECTROLIQUID

AGGREGATION +

SCULPTURAL

MATHEMATICS

RUSSELL LOWE

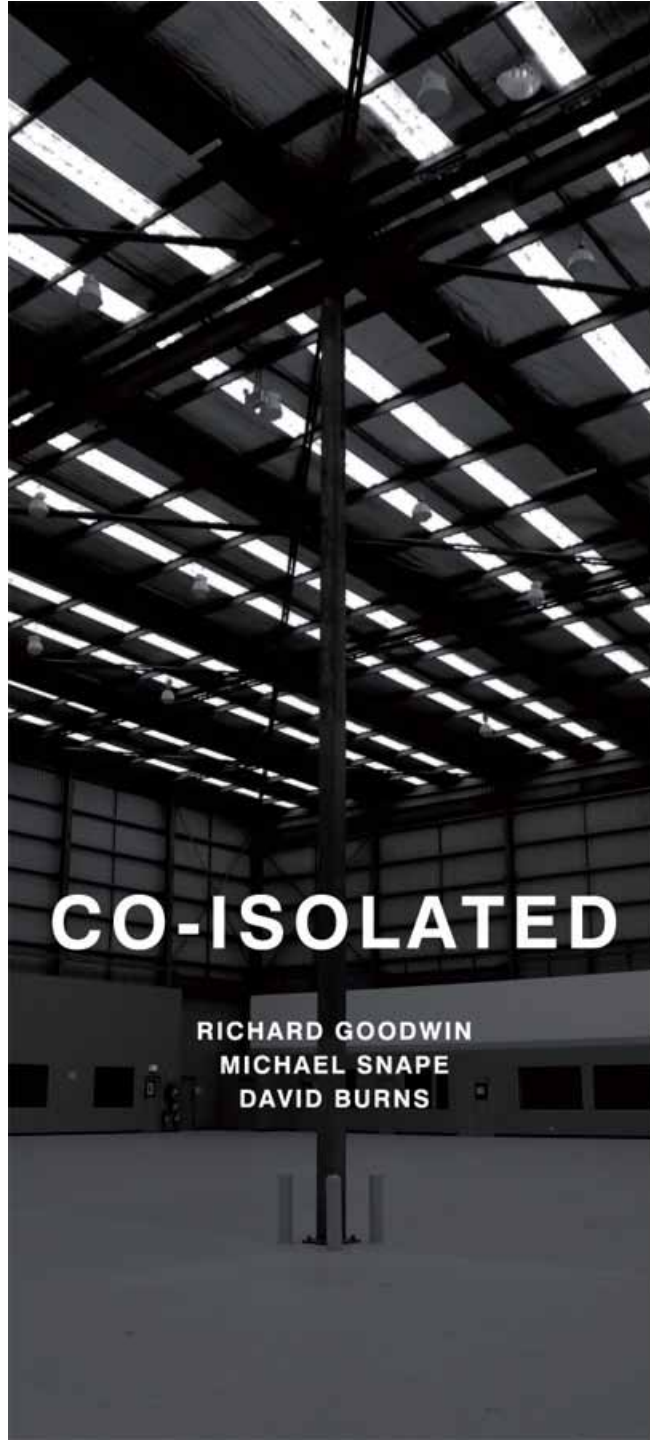

CO-ISOLATED

RICHARD GOODWIN
MICHAEL SNAPE
DAVID BURNS

CO-ISOLATED

An exhibition/event featuring new work by

**RICHARD GOODWIN
MICHAEL SNAPE
DAVID BURNS**

OPENING EVENT

Friday 16 April, 6-9pm

EXHIBITION HOURS

Saturday 17 April, 12-6pm

Sunday 18 April, 12-6pm

ARTISTS TALK

Saturday 17 April, 3-6pm

The artists will be joined by Andrew Benjamin,
Tarsha Finney, Adrian Lahoud, and others

Curated by Tarsha Finney

Building 29 / South Sydney Corporate Park
126 - 196 Bourke Road Alexandria NSW

Details and map: <http://so-ad.com/co-isolated>

School of Design
UTS
DESIGN
ARCHITECTURE
& BUILDING

SYDNEY CORPORATE PARK

School of Architecture
UTS
DESIGN
ARCHITECTURE
& BUILDING

AUSTRALIAN GALLERIES

02 9360 5177

THE SPACE BETWEEN

EXP2 INTRO

ELECTROLIQUID

AGGREGATION +

SCULPTURAL

MATHEMATICS

RUSSELL LOWE

THE CLIENTS



NICOLE KUEPPER

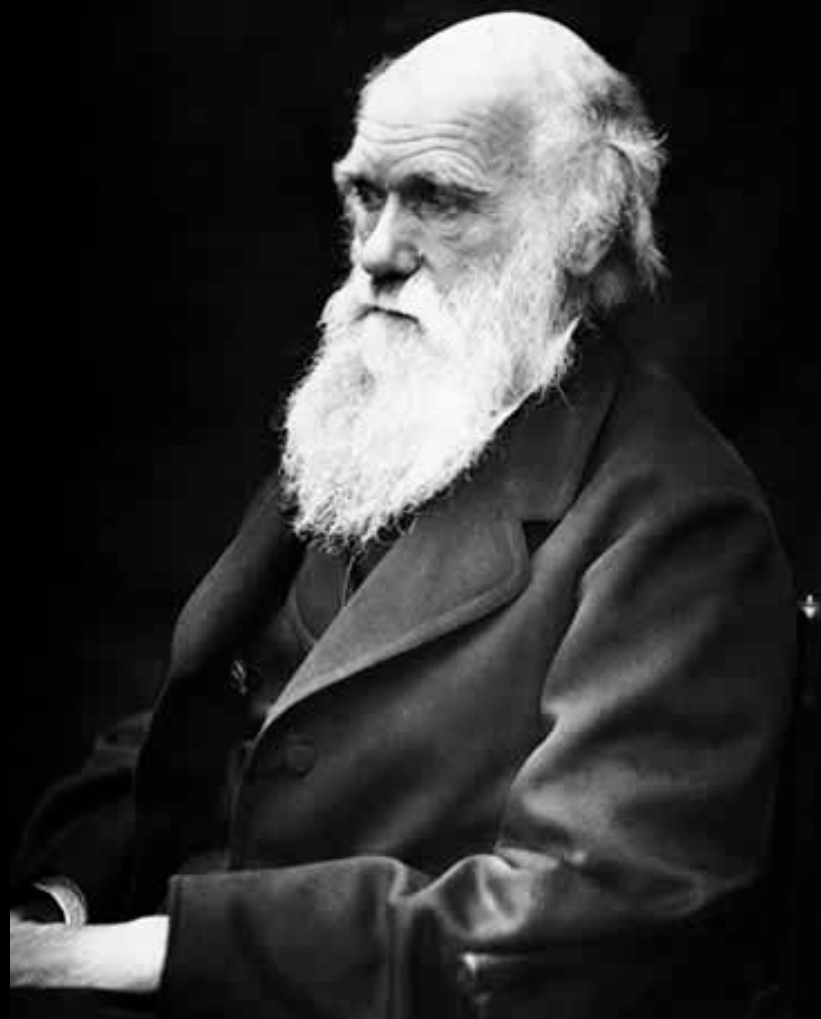

CHARLES DARWIN



STEPHEN HAWKING

THE BRIEF

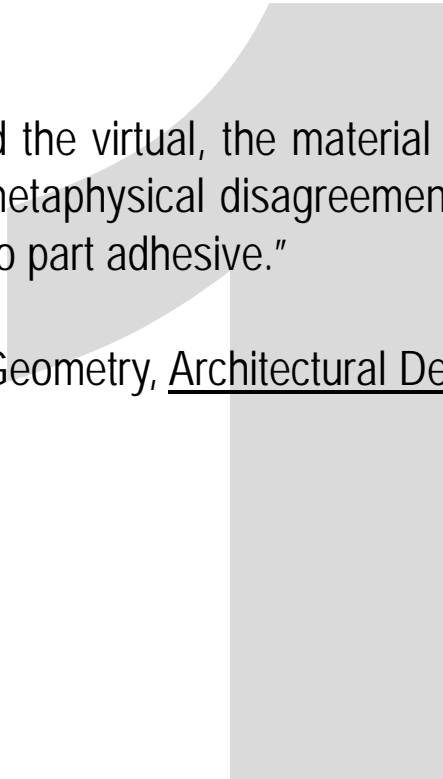

"Why still speak of the real and the virtual, the material and immaterial? Here these categories are not in opposition, or in some metaphysical disagreement, but more in an electroliquid aggregation, enforcing each other, as in a two part adhesive."

Lars Spuybroek, [1998] Motor Geometry, Architectural Design, Vol 68 No 5/6, p5

LARS SPUYBROEK



Neutelings and Riedijk *ON laziness recycling sculptural mathematics & ingenuity.*
El croquis 94.

“Laziness, one of the seven cardinal sins, is one of (a designers) most useful characteristics. The combination of diligence and ambition is highly dangerous; the combination of laziness and ambition ensures a pleasing balance, which often leads to happy results because compensating for laziness requires the application of ingenuity.”

Recycling Typologies and Concepts.

Sculptural Mathematics: “The most exhausting sort of design process is one in which each version requires a conscious decision. We therefore make it our practice to start off with a simple basic mathematical concept within which the program is to be organized.”

Conclusion: “Nevertheless, no matter how successful it might be as a method, (laziness) still has a great disadvantage: it requires a lot of effort.”

NEUTLINGS + RIEDIJK

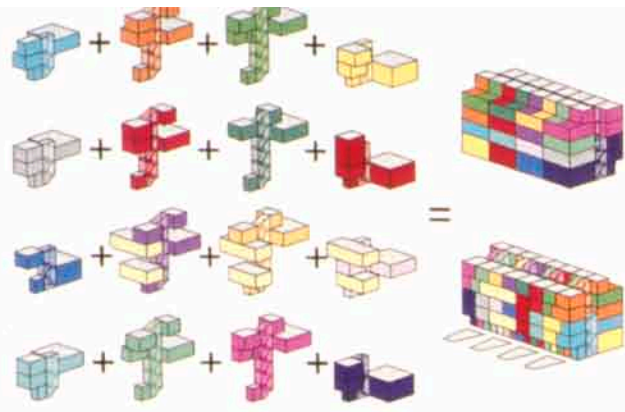

GWL AMSTERDAM

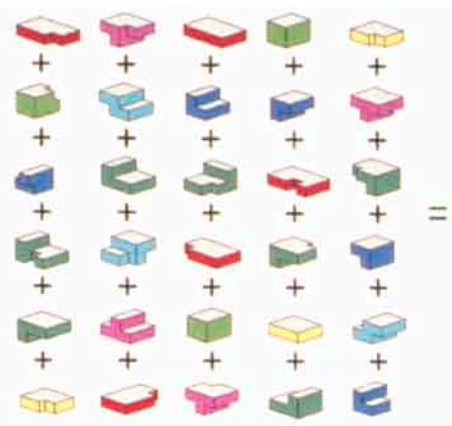

DEN HAAG

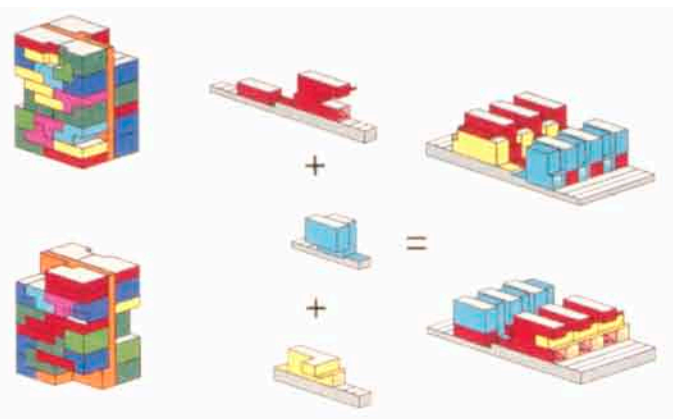

BORNEO SPORENBURG

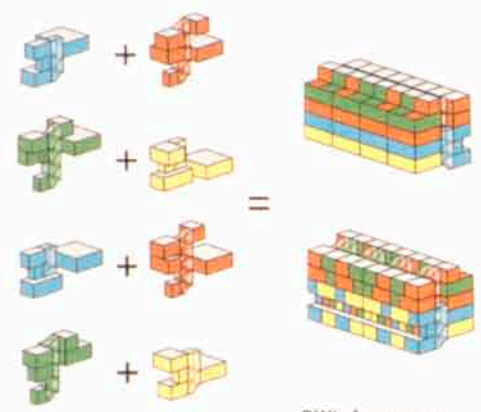

GWL AMSTERDAM

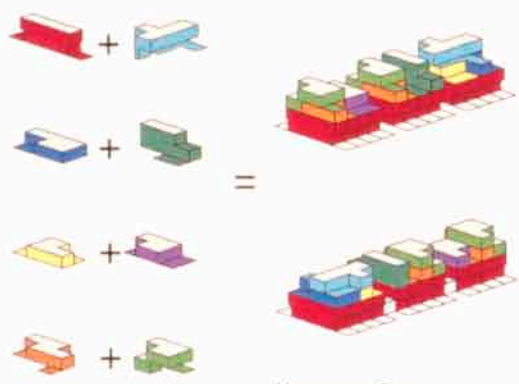

HOLLAINHOF GENT

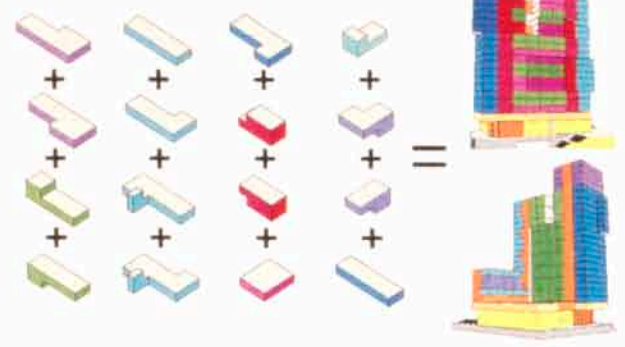

WIJNHAVEN ROTTERDAM

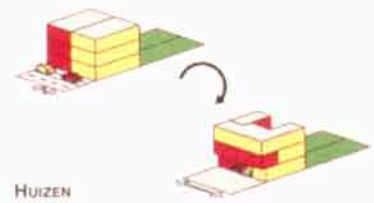
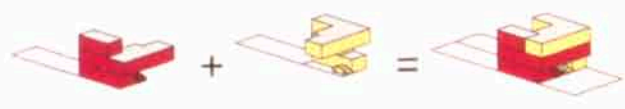

HUIZEN

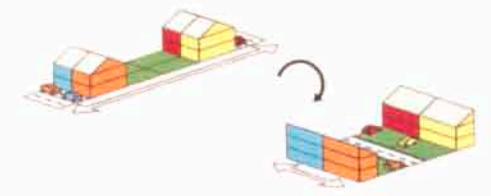

IJSSELSTEIN

Diferentes estudios volumétricos/tipológicos para viviendas
 Different volumetric/typological studies for dwellings

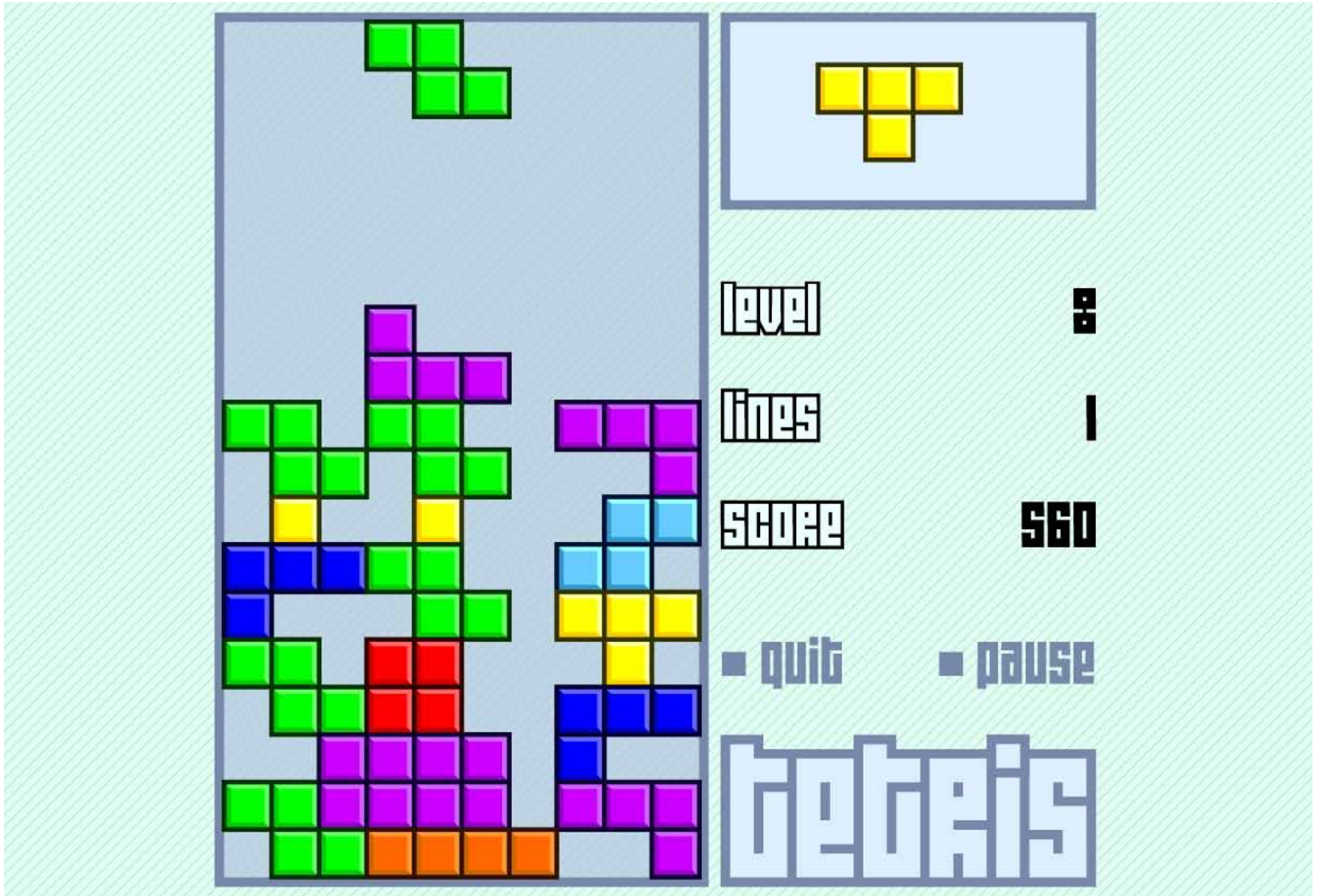

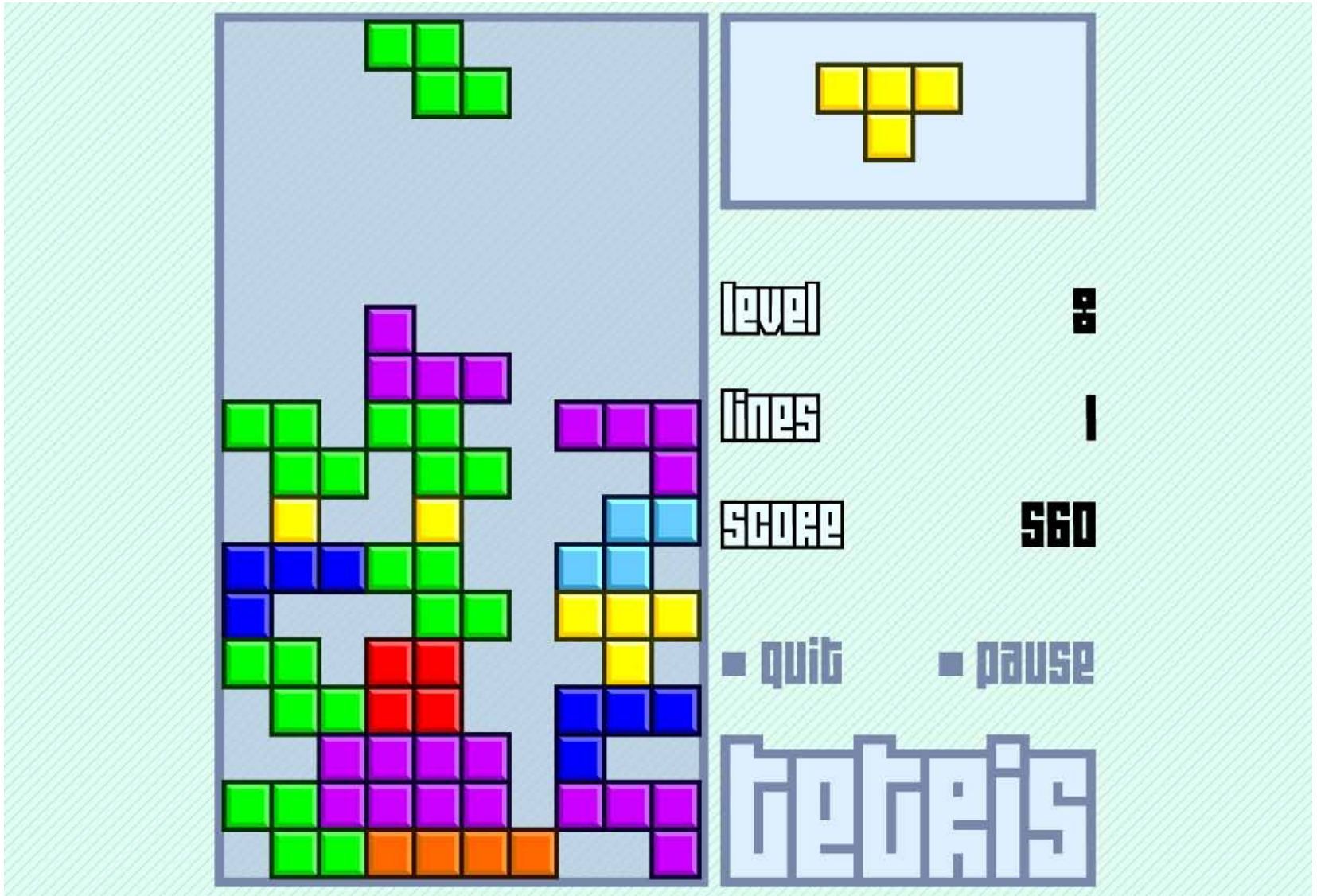

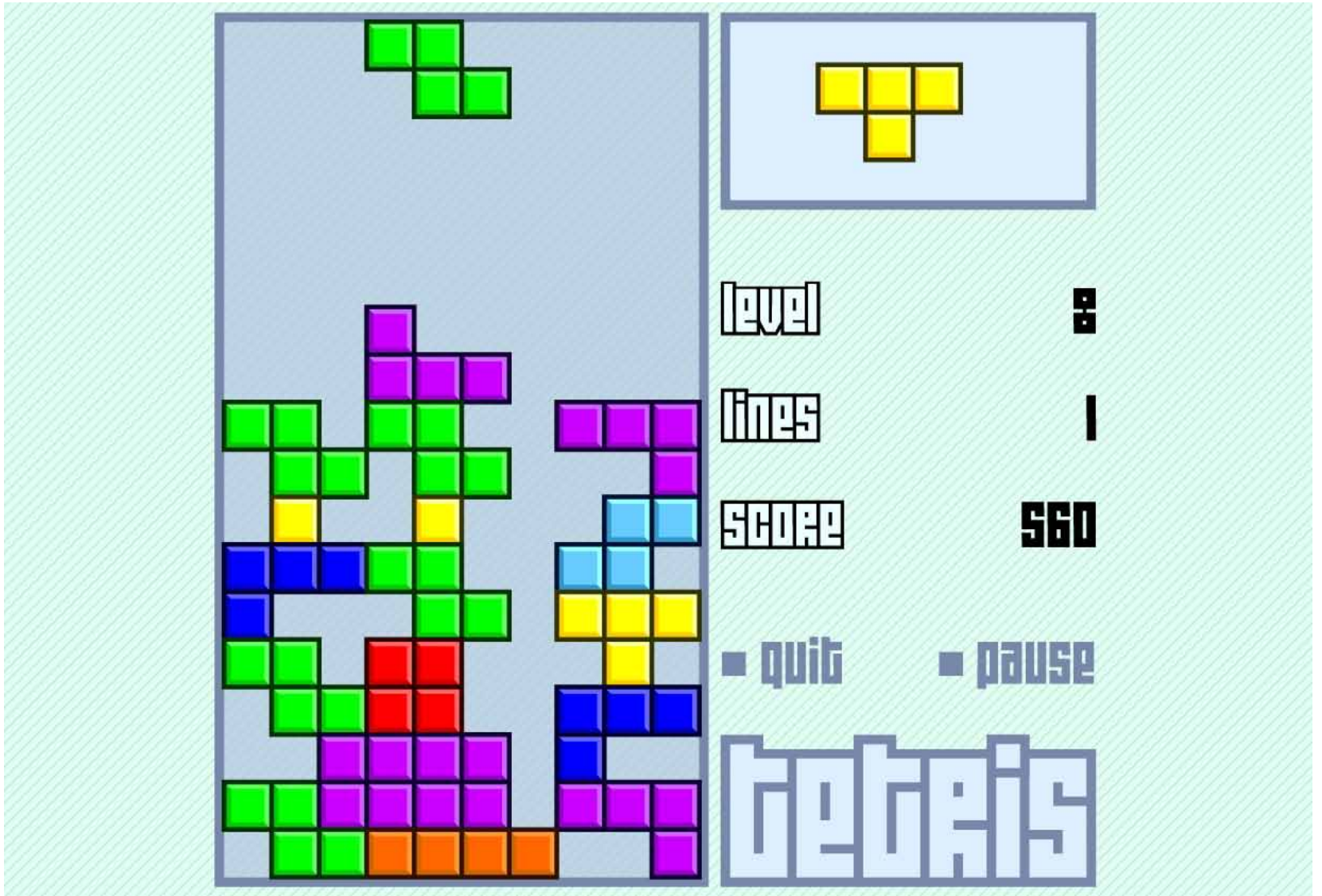

MINNAERT BUILDING. UTRECHT.

Neutelings and Riedijk. El croquis 94.

NEUTLINGS + RIEDIJK

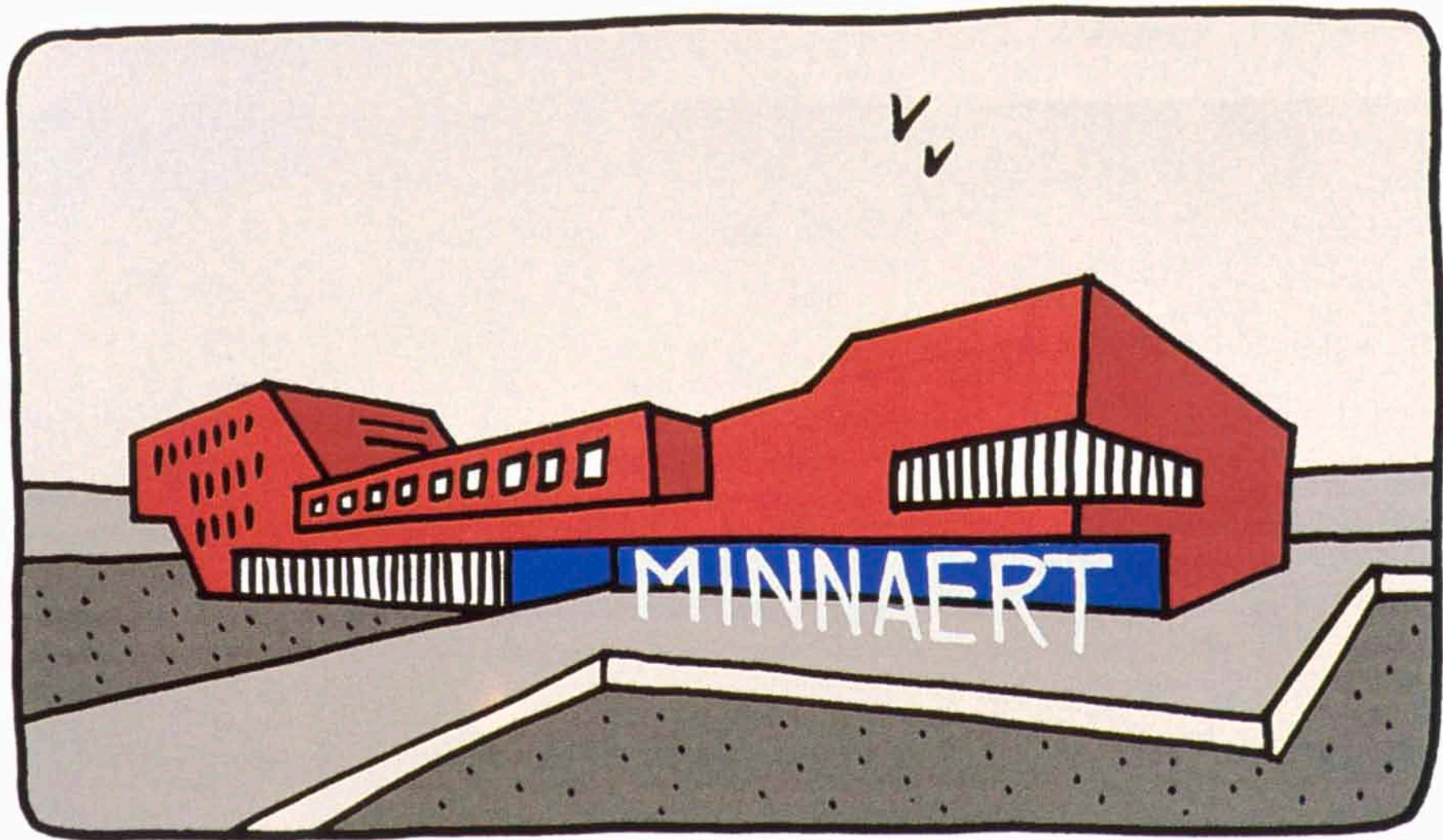



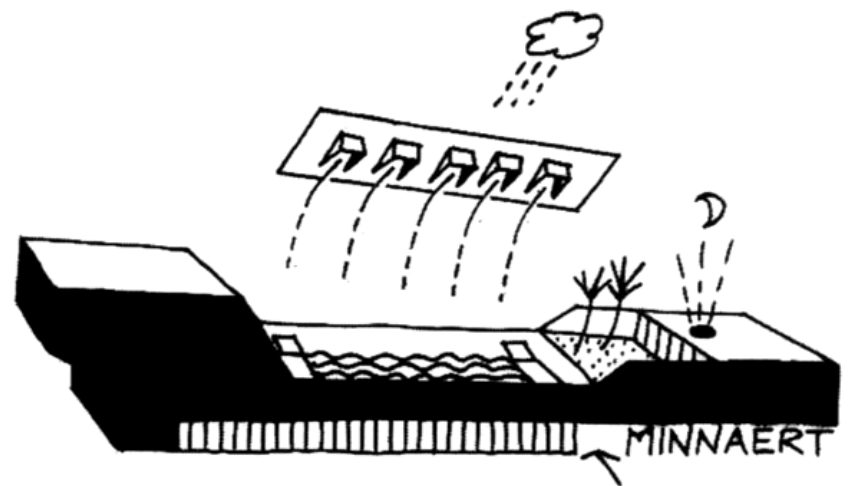
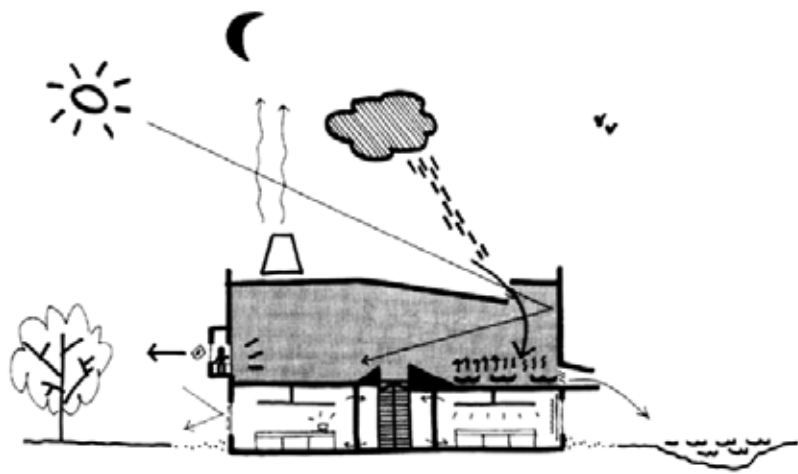





Discussions

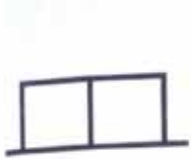

161094
2 Storeys 14 deep



231194
4 Storeys 7 metres deep
No wide views to park

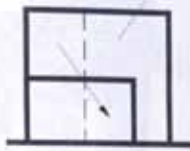

141294
House in a house
No roof access house 1
Small garden access house 2



231295
Alternating floors 1
No roof access house 1

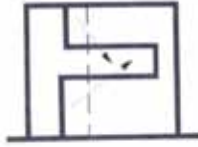

040194
Alternating floors 2
Too little garden access for house 1

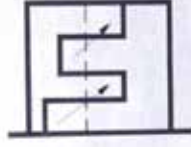

120195
Alternating floors 3
Too little garden access for house 1

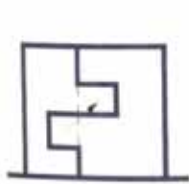

200295
Alternating floors 4
Wider garden access + roof access



090395
Outdoor space
Roof terrace house 1
Garage + roof terrace house 2



130495
Final result
Bedrooms in 1 + 2
Plausible house 2
pass. fire regulations



MRV DV

**RECYCLING
TYPOLOGIES
+ CONCEPTS**

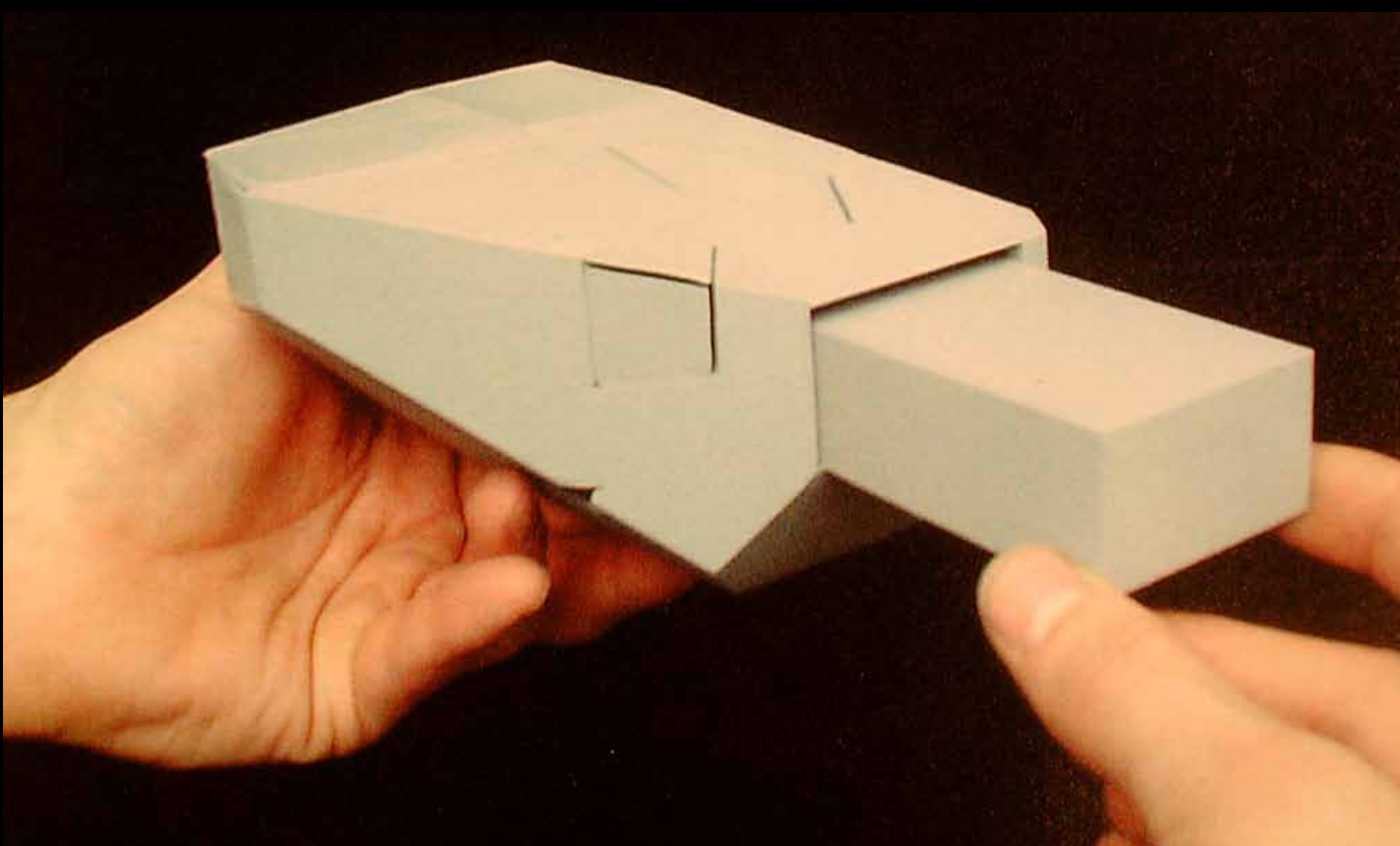

REM KOOLHAAS

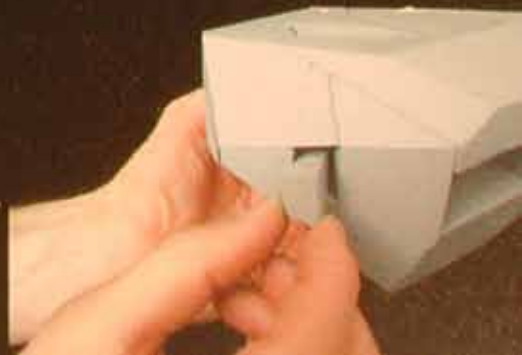
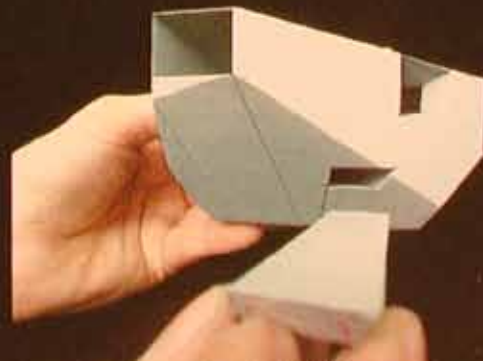
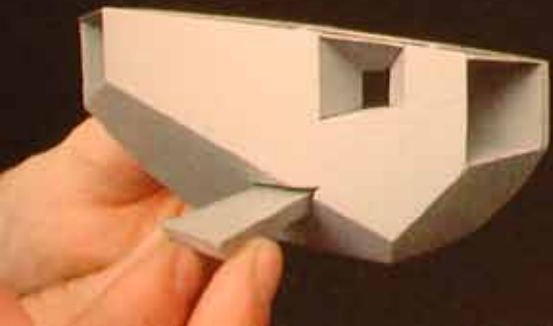
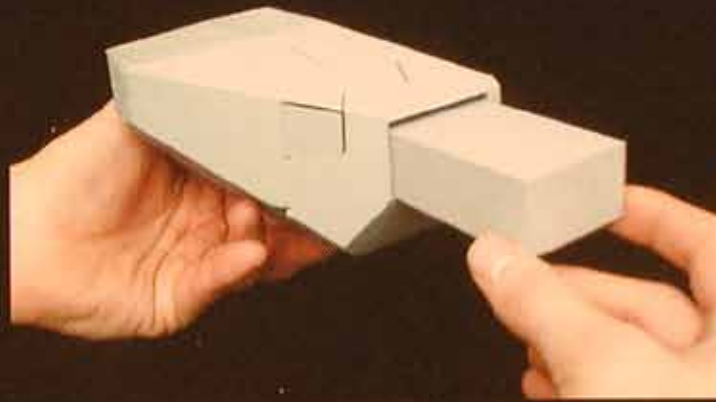
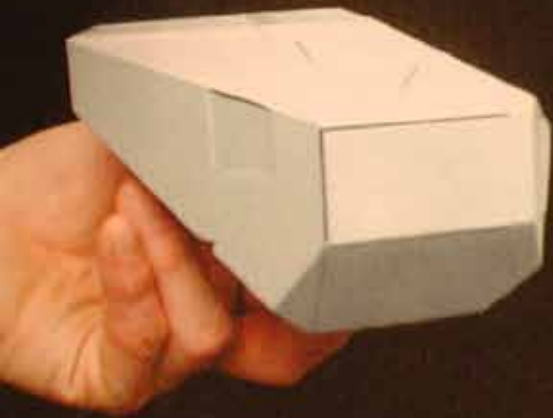

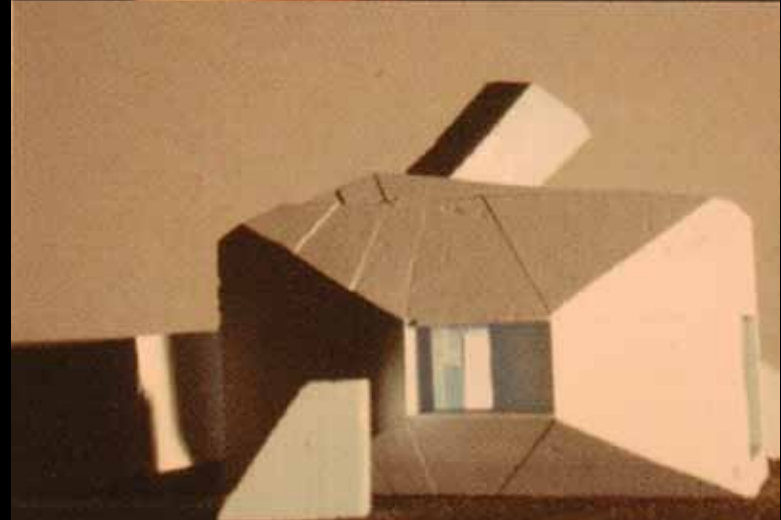
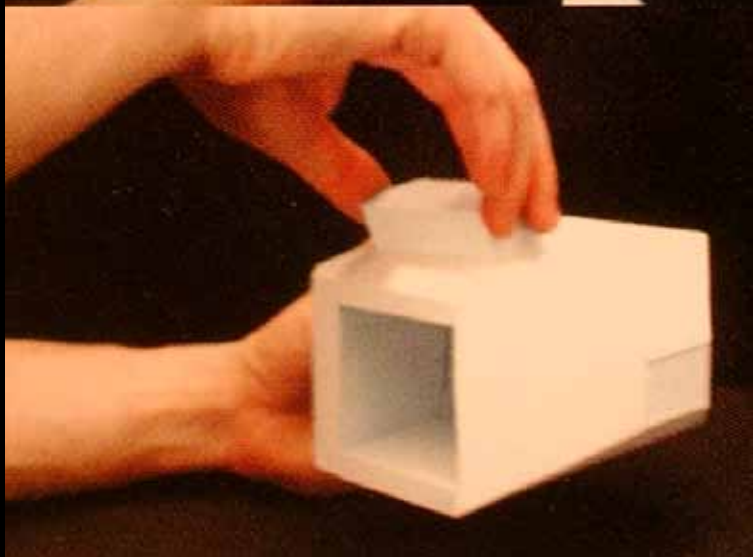
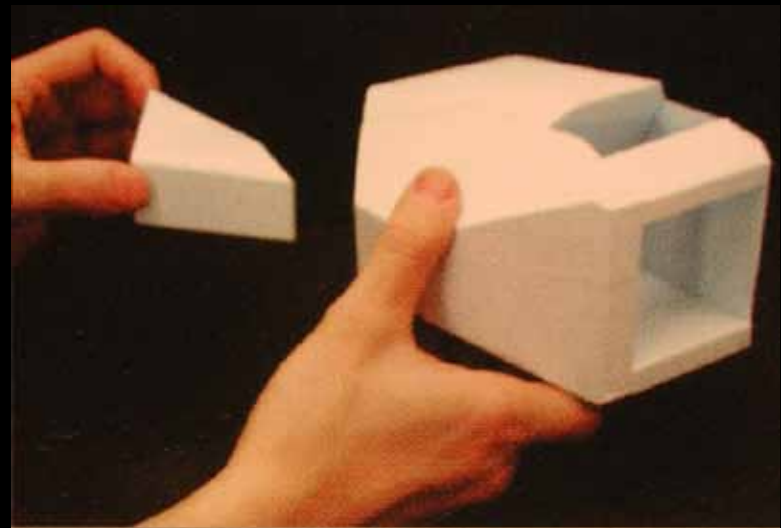
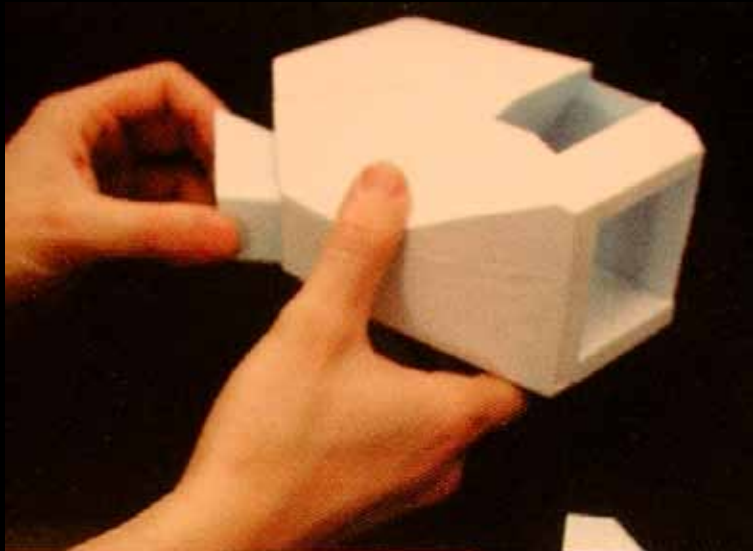

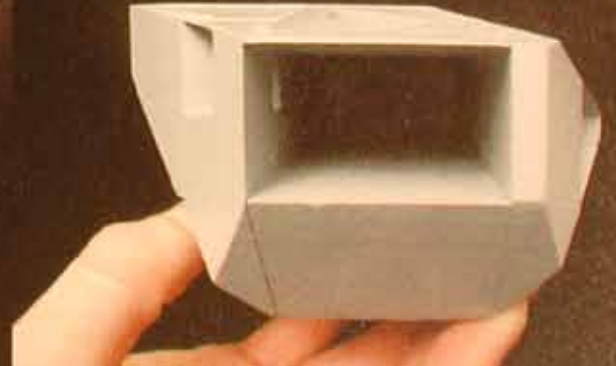
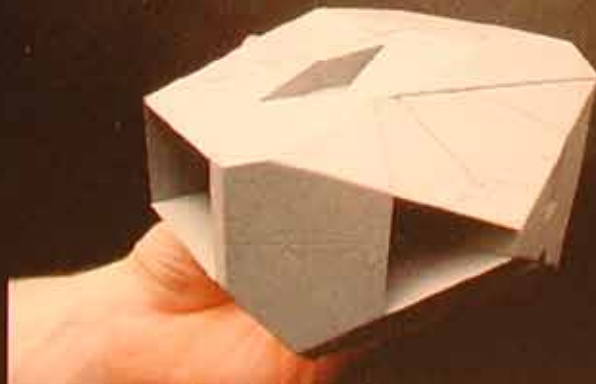
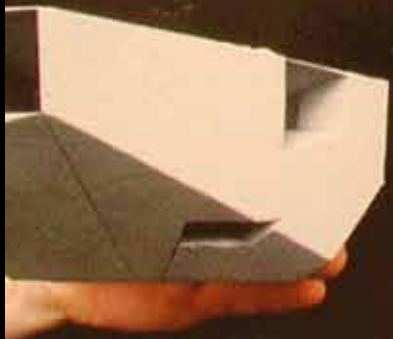
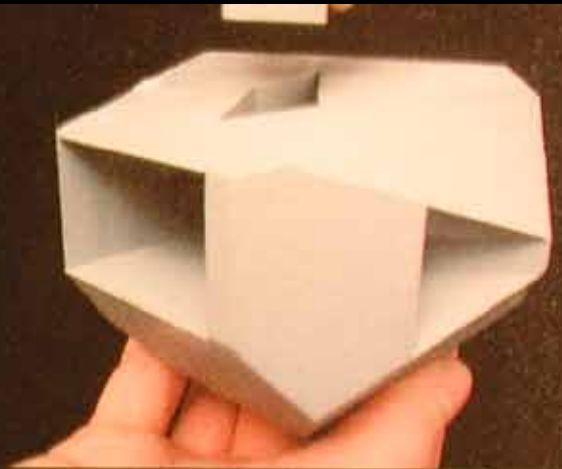
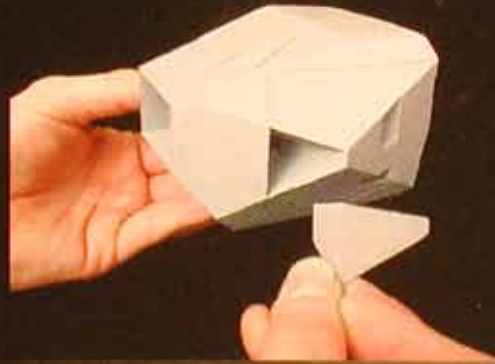
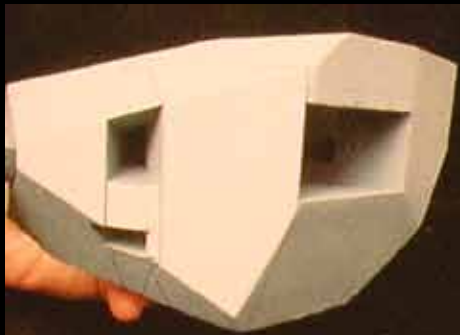



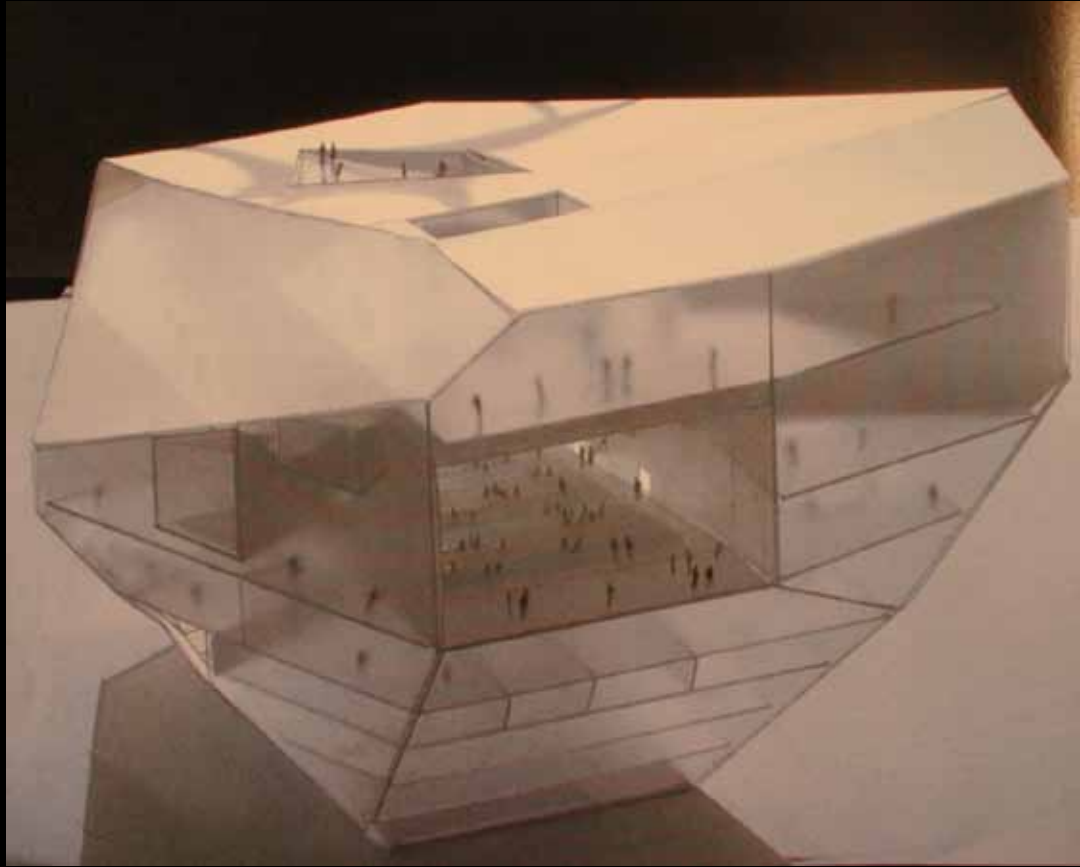

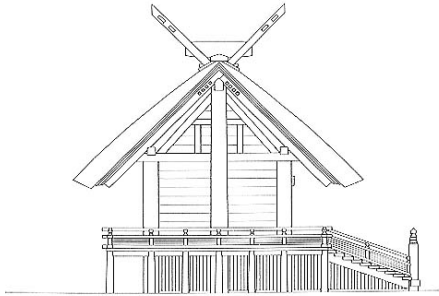
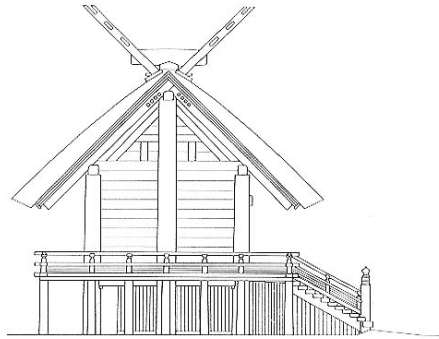

ISE SHRINE



© Alex Vertkoff / The Gamble House



© Matt Jalbert / The Gamble House



© Matt Jalbert / The Gamble House

GREEN & GREEN



PIER LUIGI NERVI

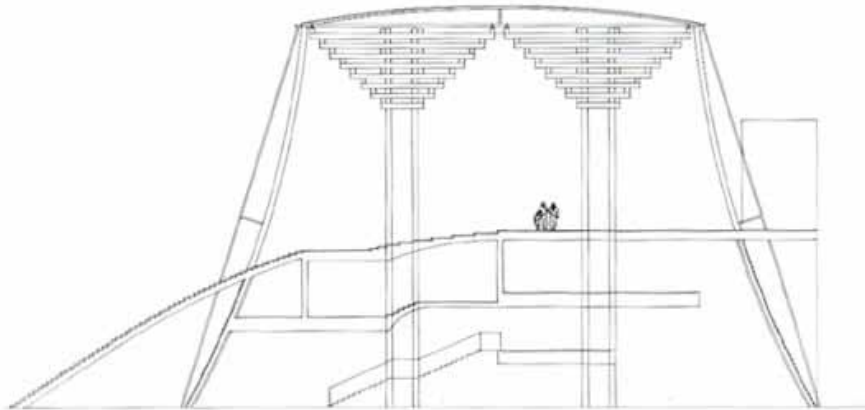

TADAO ANDO



TADAO ANDO

**RACHAEL
WHITEREAD
MEMORY**

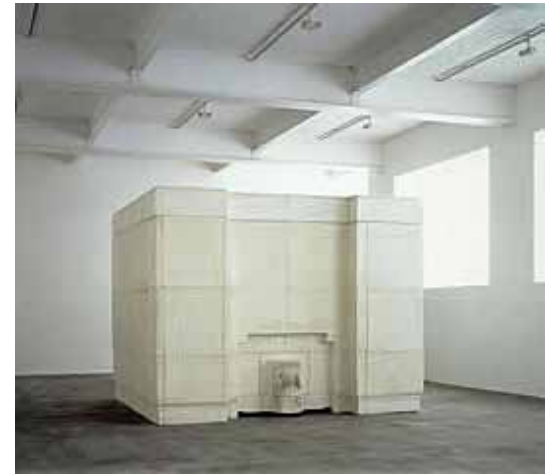
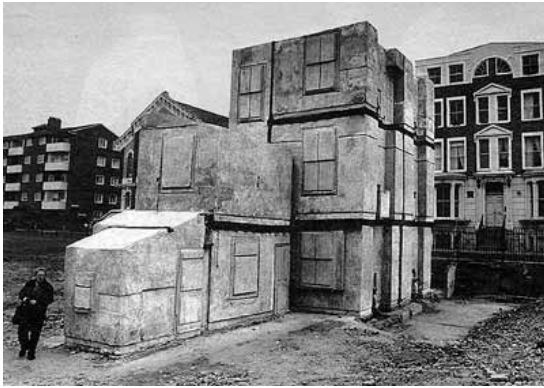



Rachel Whiteread "Sin Título (Doméstica)"











PETER EISENMAN

RICHARD SERA

MEMORY



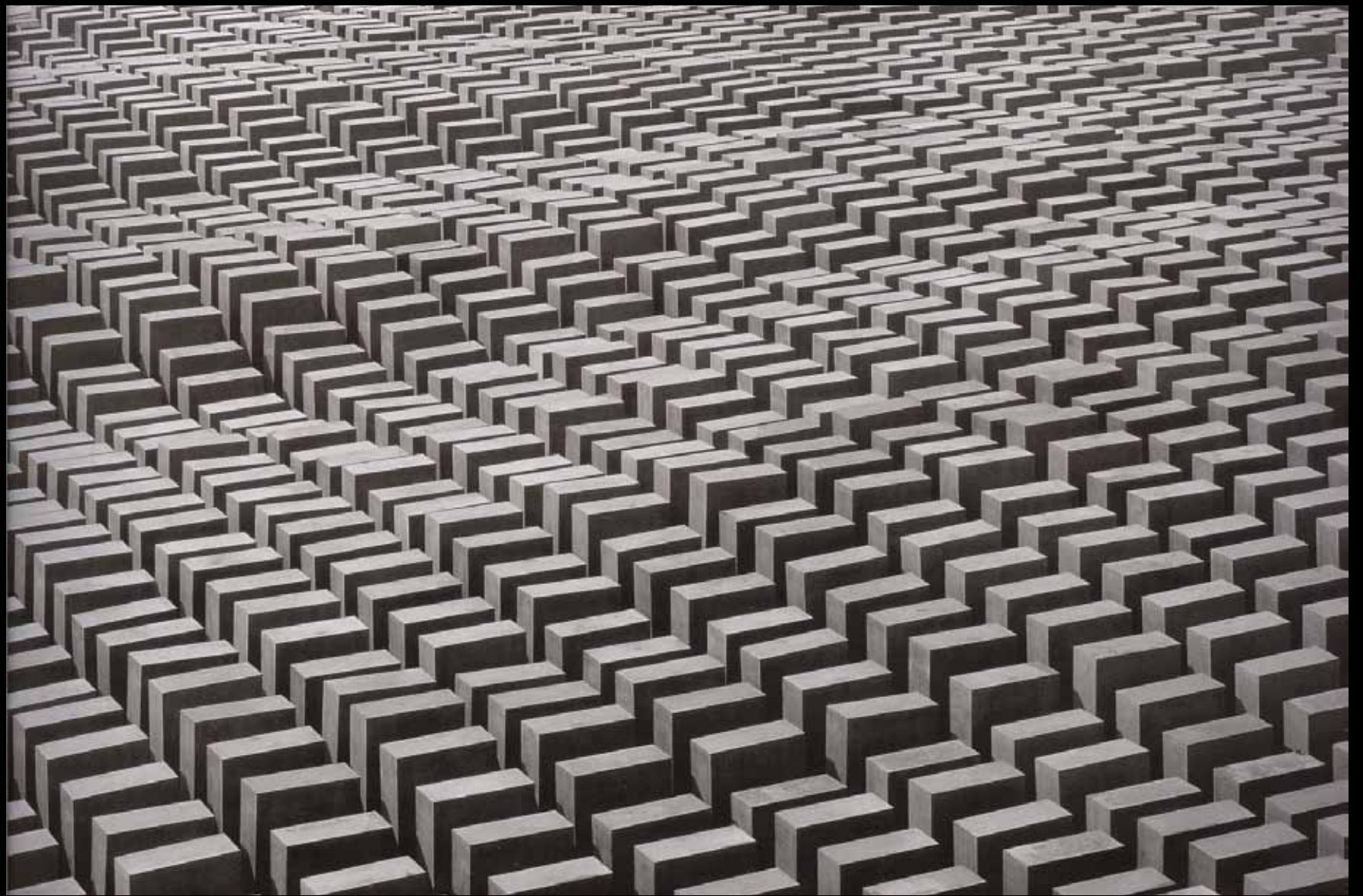



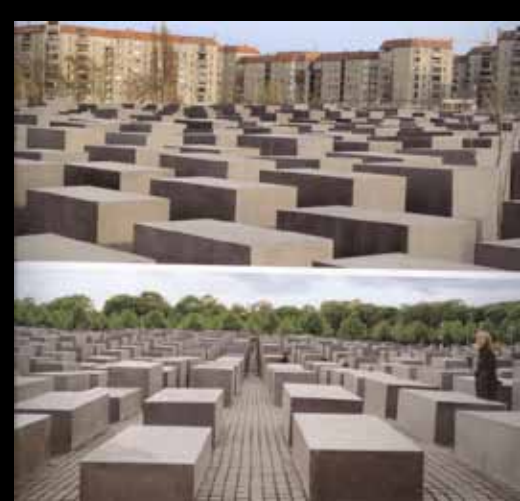

**PARALLEL
PROJECTION
AXONOMETRIC
ISOMETRIC**

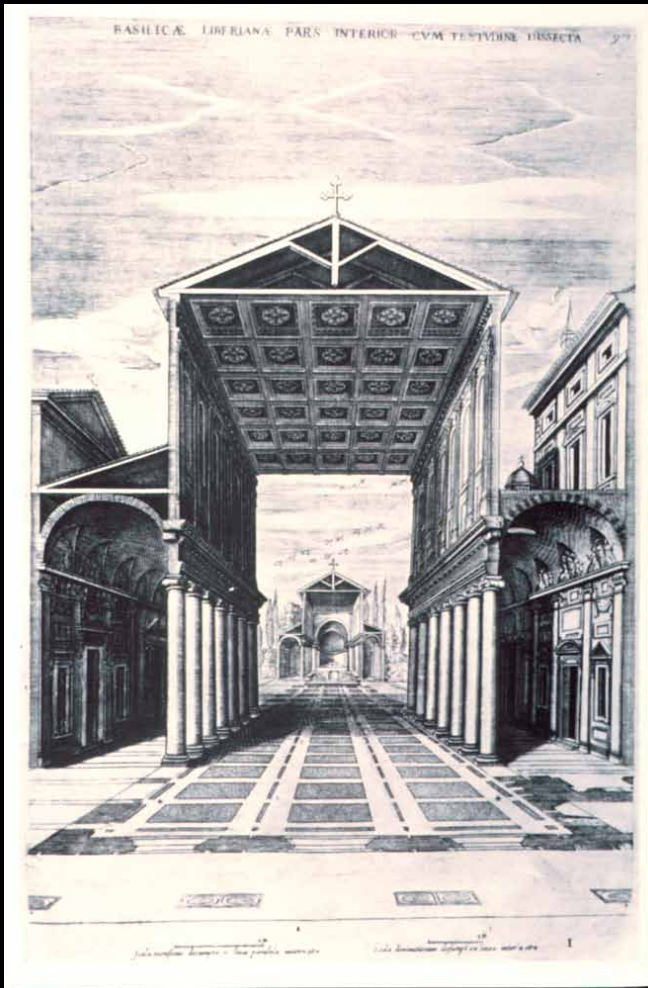

PERSPECTIVE [ONE POINT]

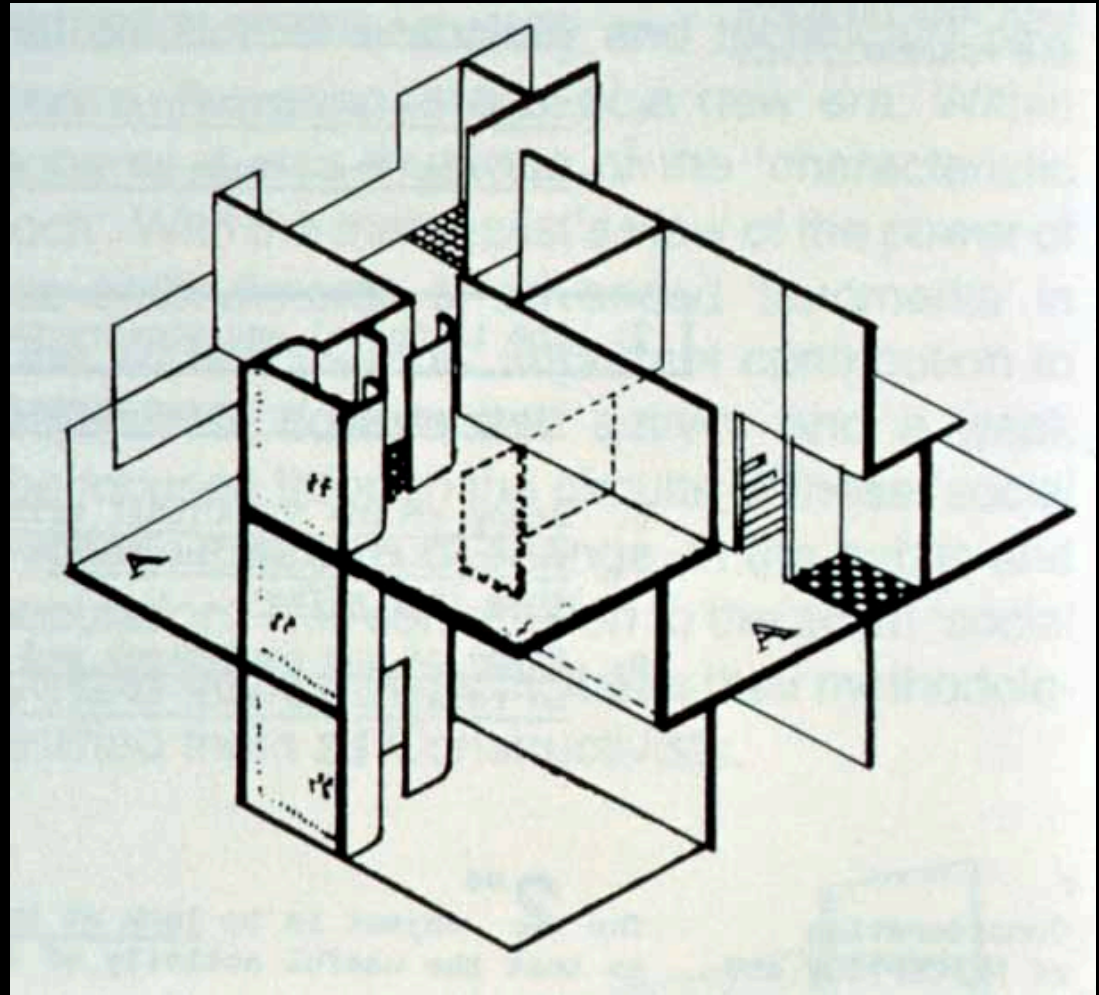

PARALLEL PROJECTION [ISOMETRIC]

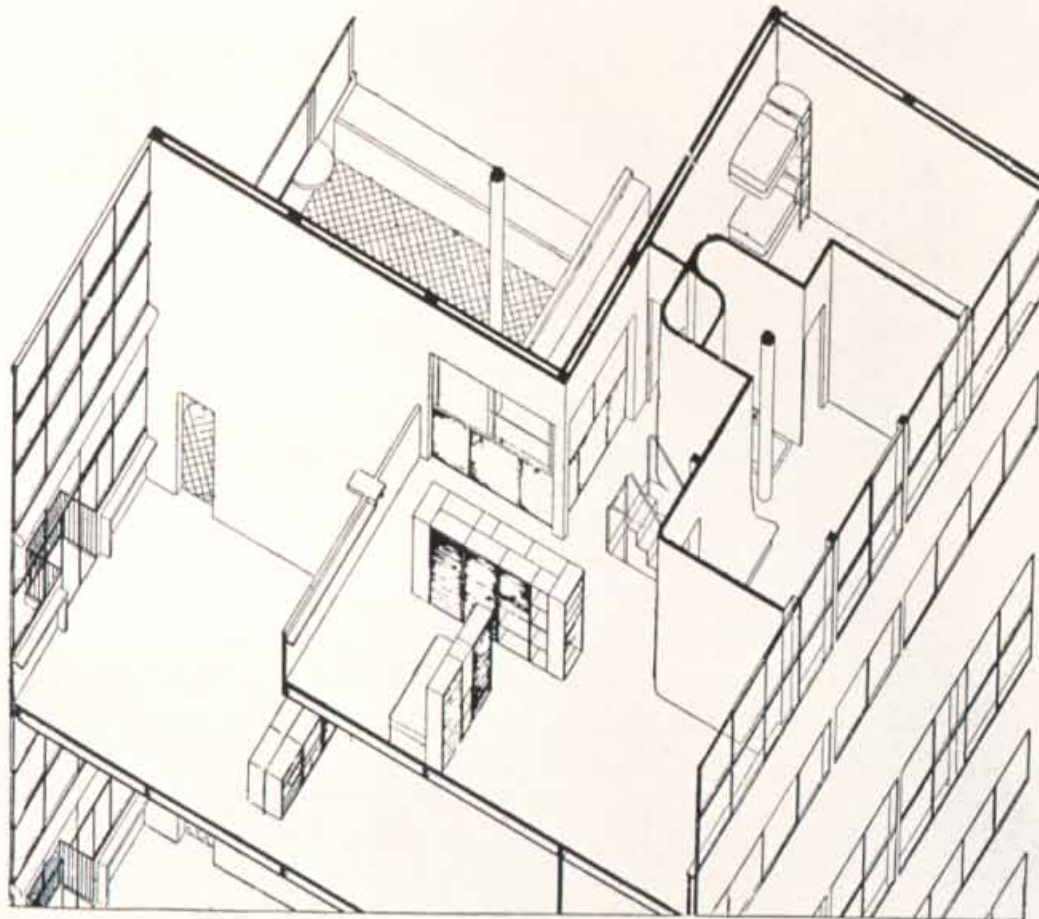

Le Corbusier und Pierre Jeanneret:

axonometric cons

The extent to
 the "meta-design"
 presented through
 Ludwig Hilberseim
 reorganization and
 pedestrian traffic, p
 is icastically summe
 not attempt to inf
 principle. In fact, th
 cago.²² The drawing
 effect of reality ha
 servient to the prin
 of fixtures are indic
 the figure, which c
 sample. In order to
 axonometry still fu
 the figure. But the
 drawing, of a varian
 perimpression acts a
 employed to susper

Just how far the
 pective and to axon
 in the case of Hilber
 ing at the bottom rig
 "Hochhausstadt" wh

AXONOMETRIC [USUALLY ROTATED BY 45 DEGREES AND USES PLAN DIRECTLY]

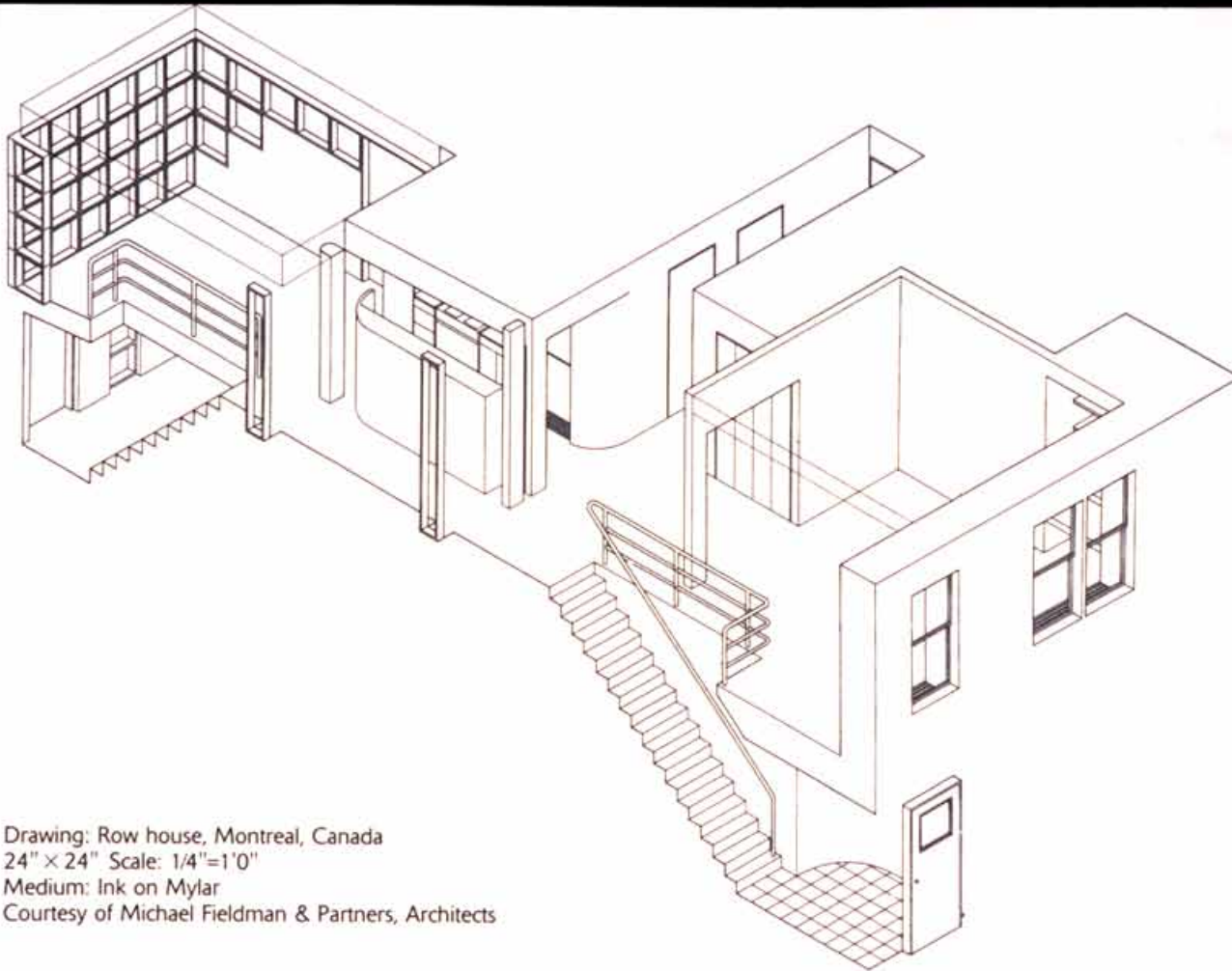

Drawing: Row house, Montreal, Canada
24" x 24" Scale: 1/4"=1'0"
Medium: Ink on Mylar
Courtesy of Michael Fieldman & Partners, Architects

AIRWAYS

ISOMETRIC [USUALLY 30 DEGREES IN BOTH DIRECTIONS OFF BASELINE AND MUST REDRAW PLAN]

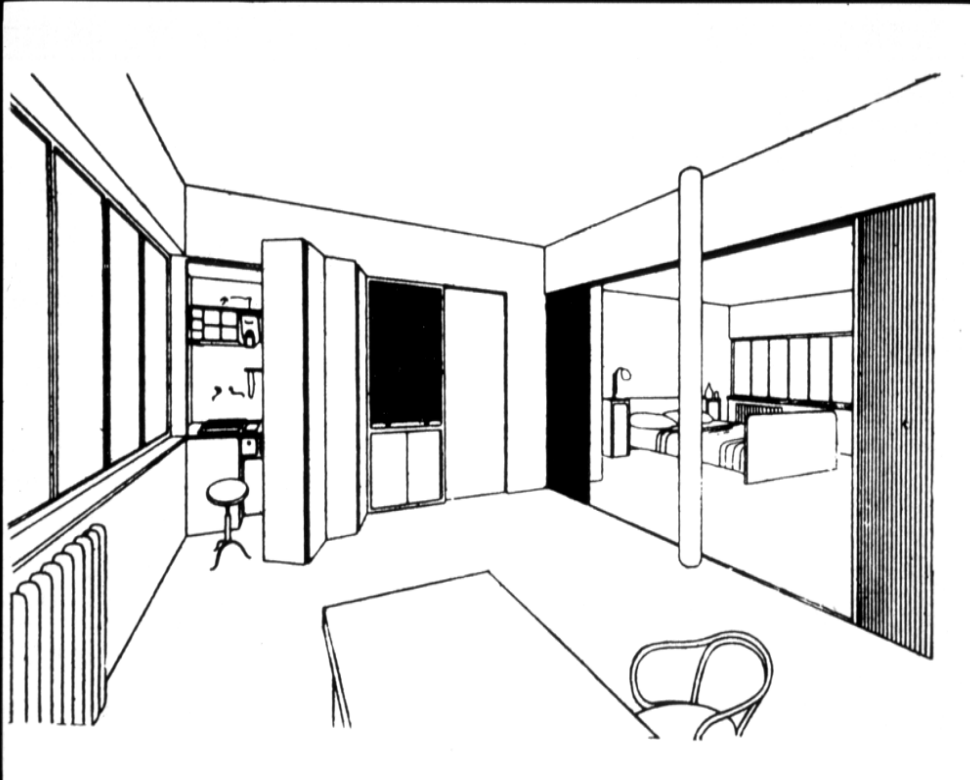

PERSPECTIVE [TWO POINT]

ästhetischer und theosophischer Erwägungen
 zur Axonometrie².
 vorangestellten Zitat: Wenn man, wie Bruno
 Axonometrie tatsächlich als „symbolische

axonometry grew out of his occult and the
 dimension.²

Bragdon's enthusiasm makes it quite
 indeed, as Bruno Reichlin suggests, seem

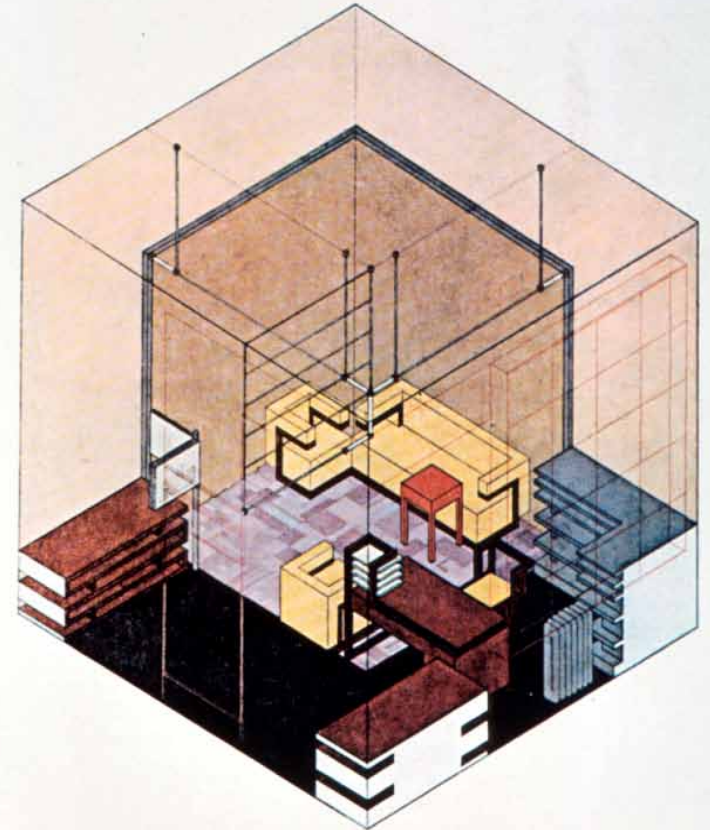

Herbert Bayer
 Das Atelier Walter Gropius im Bauhaus Weimar,
 1923. Isometrie

Herbert Bayer:
 The office of Walter Gropius at the "Bauhaus"
 1923, Isometry

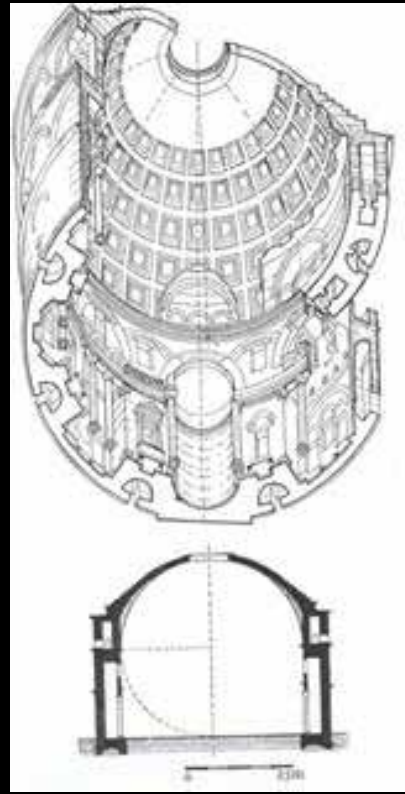
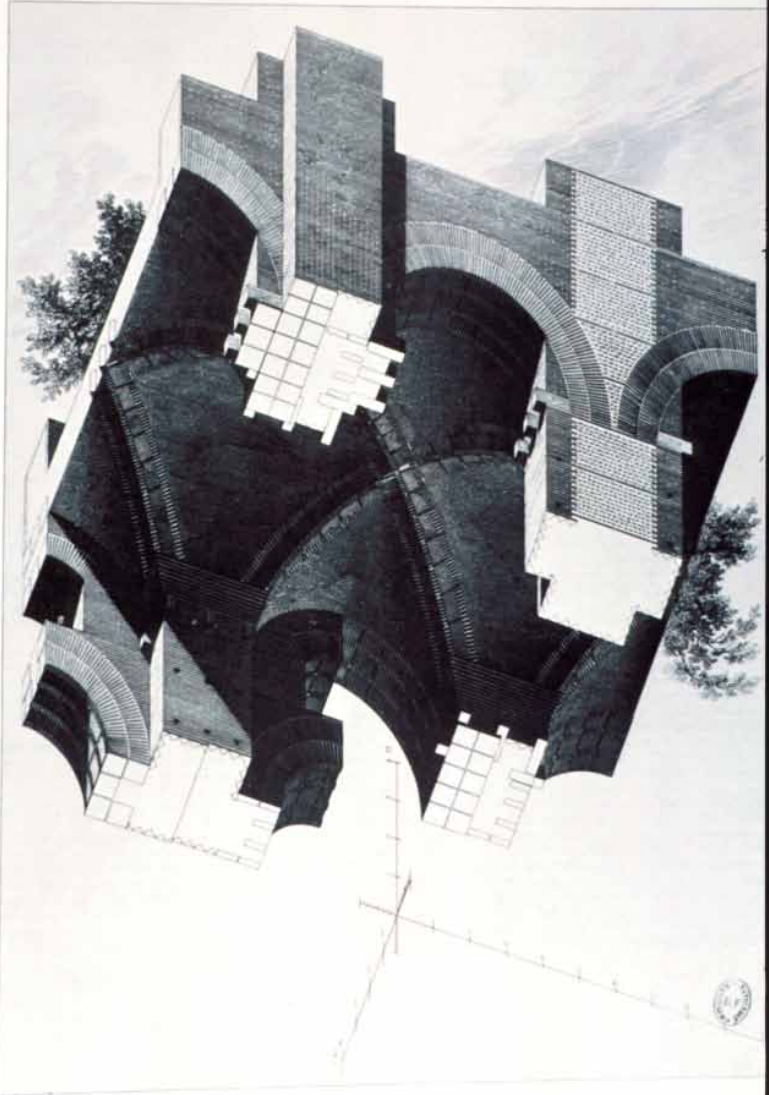

n House, 1968.
or projection.
in Primärfarben –
schwarz, Weiß, Grau.
or primaries –
black, white, gray;

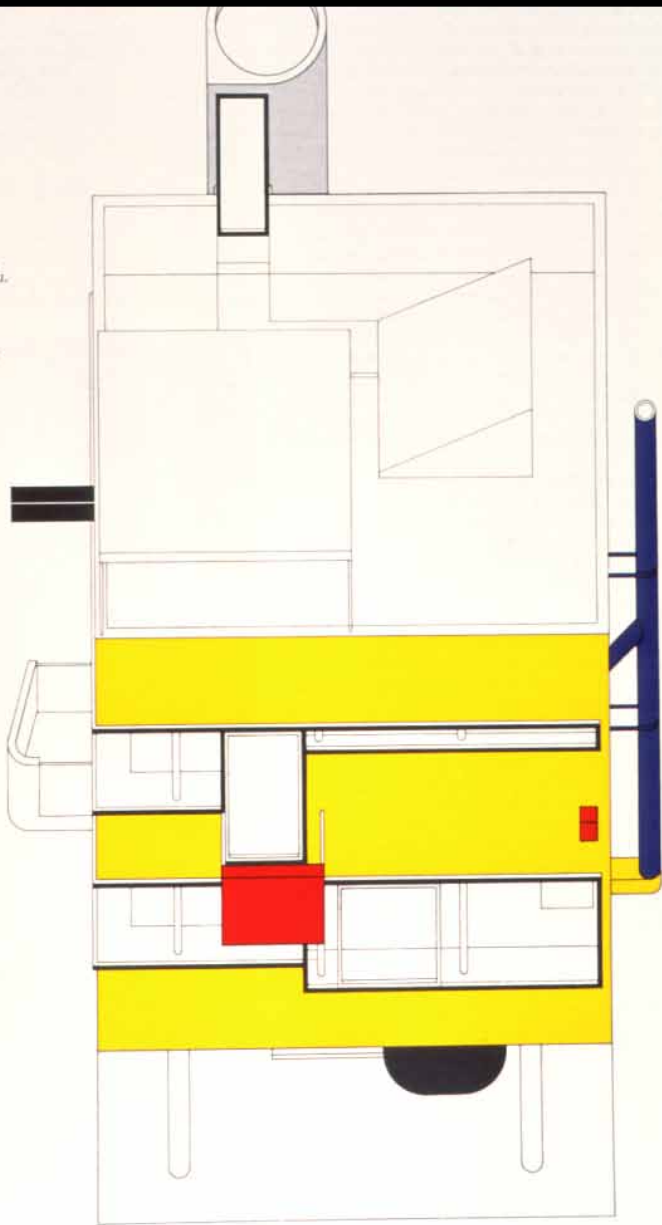

berto Sartoris.
udio in the ideal house of
e architect in Florence, 1942.

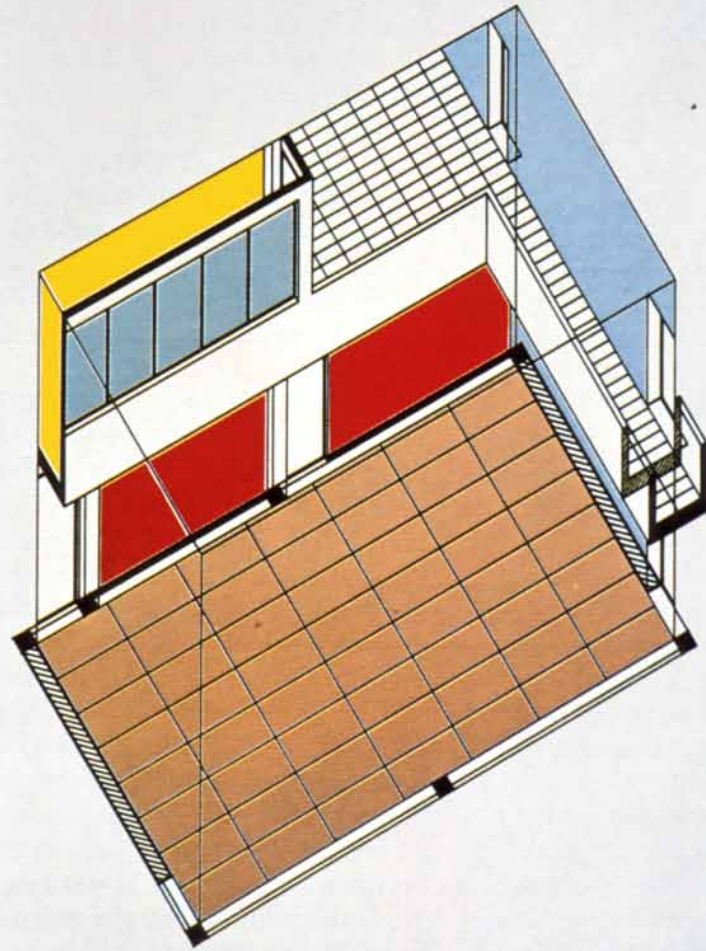

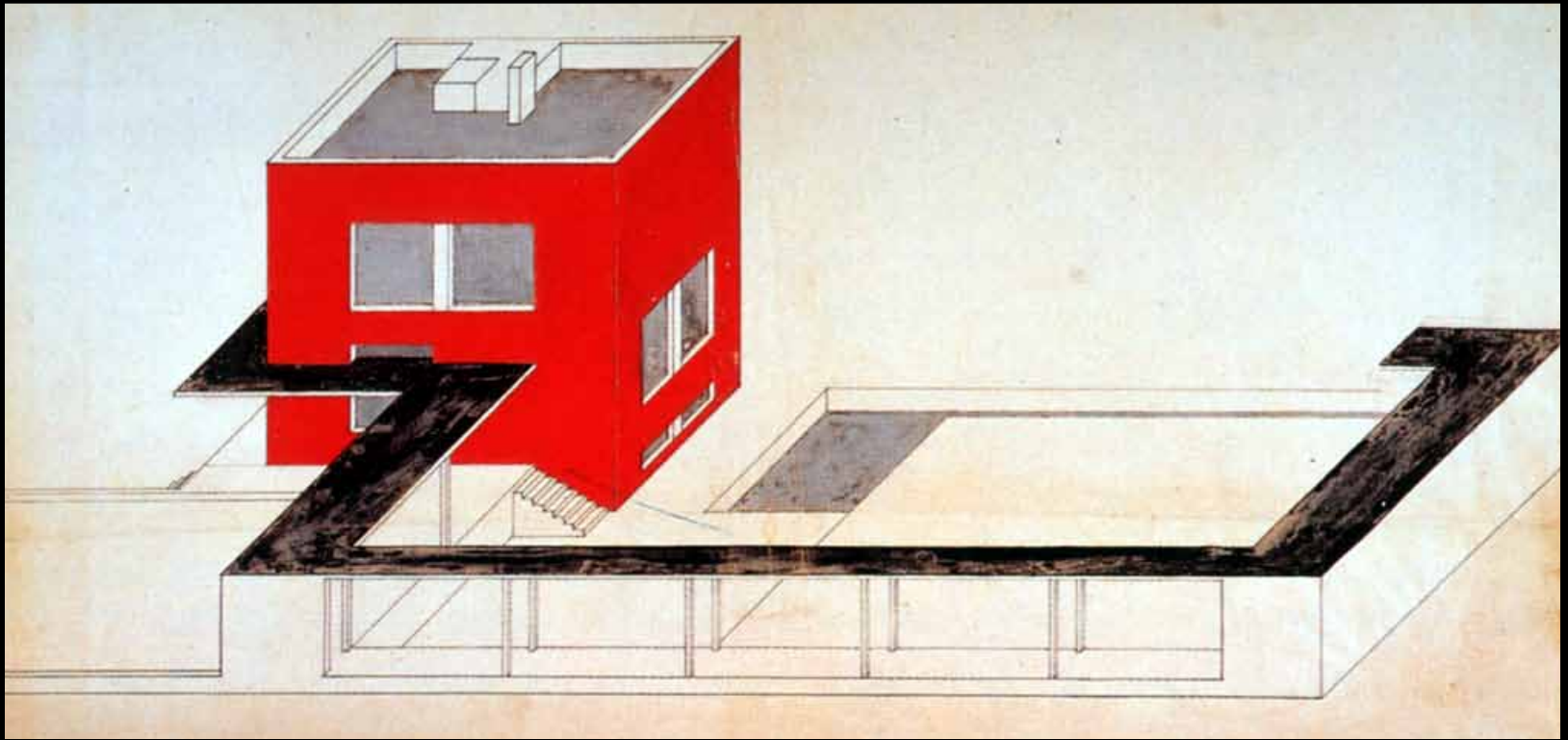

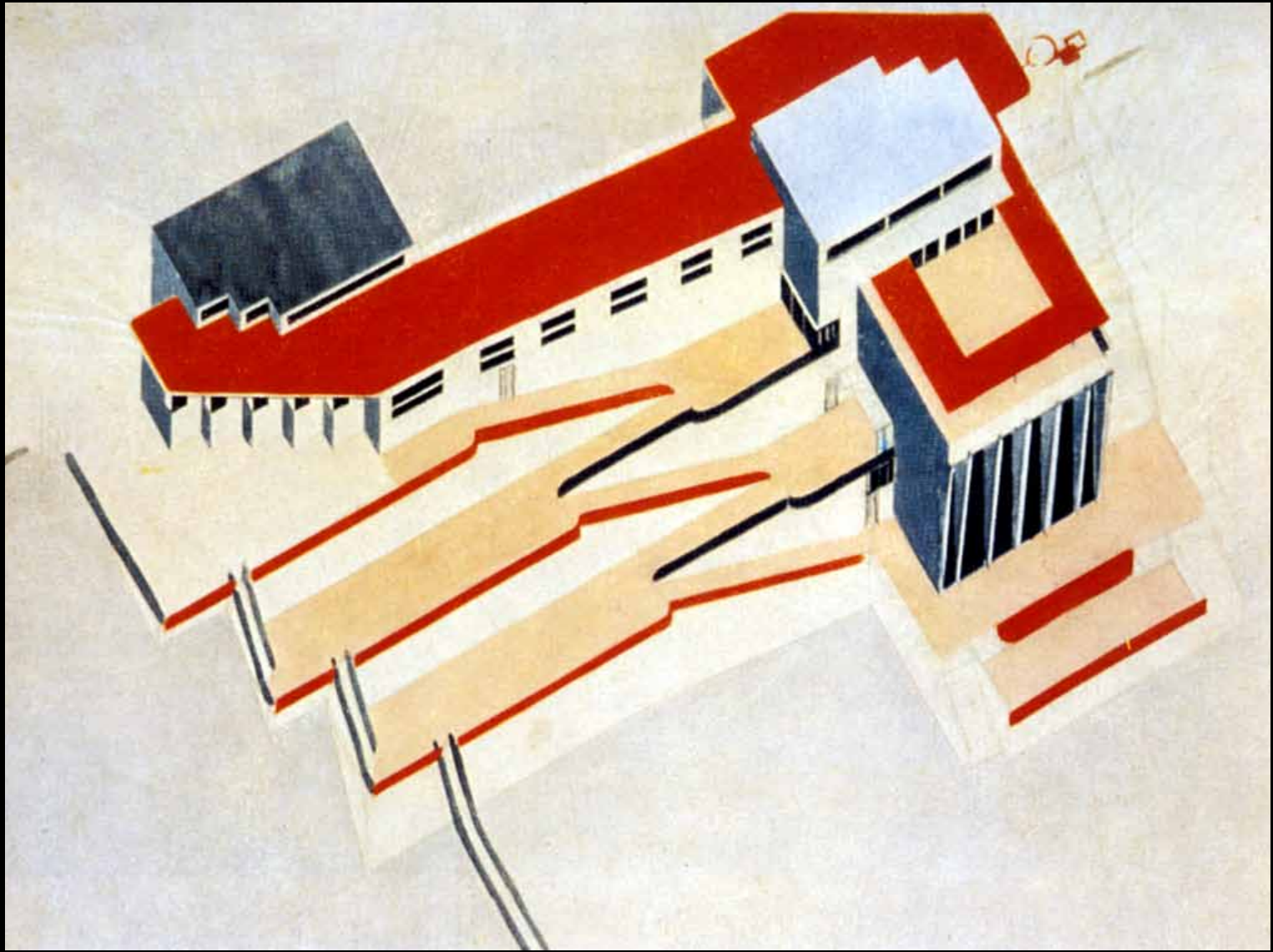

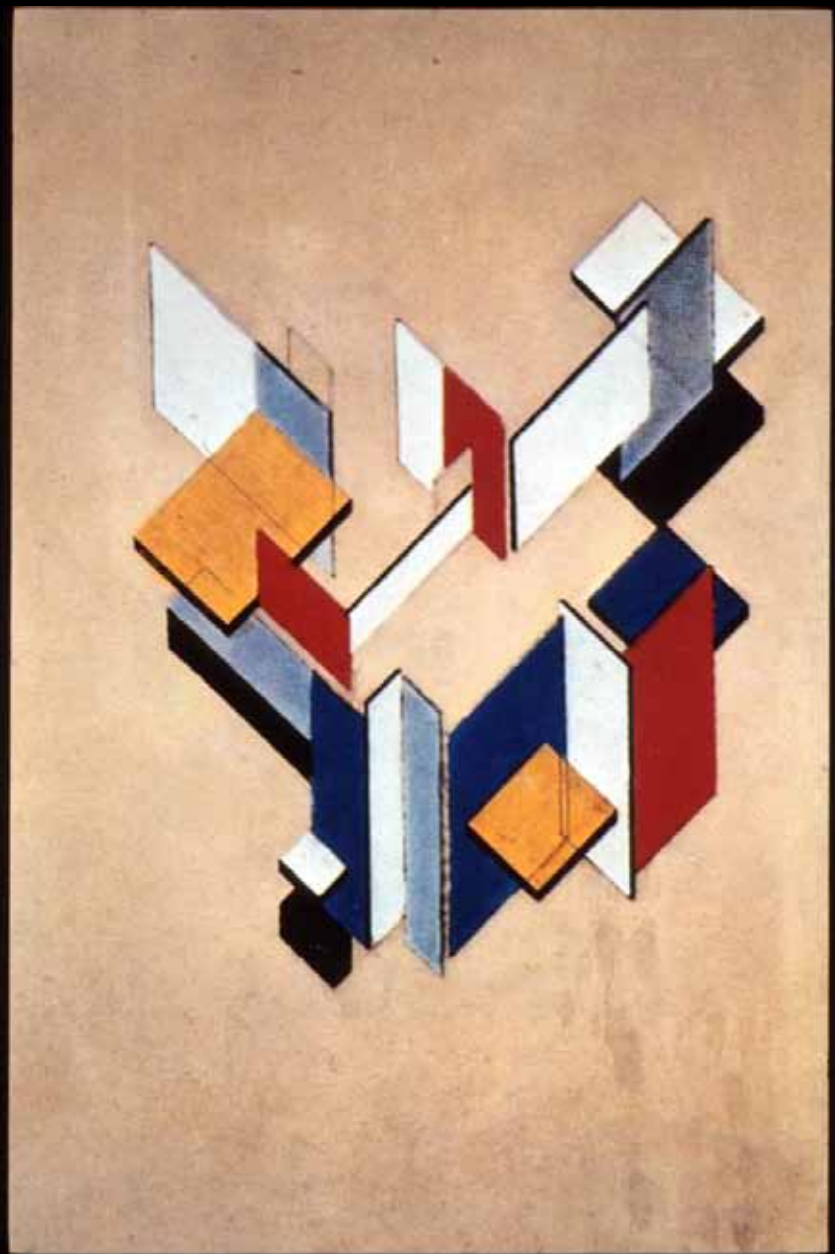
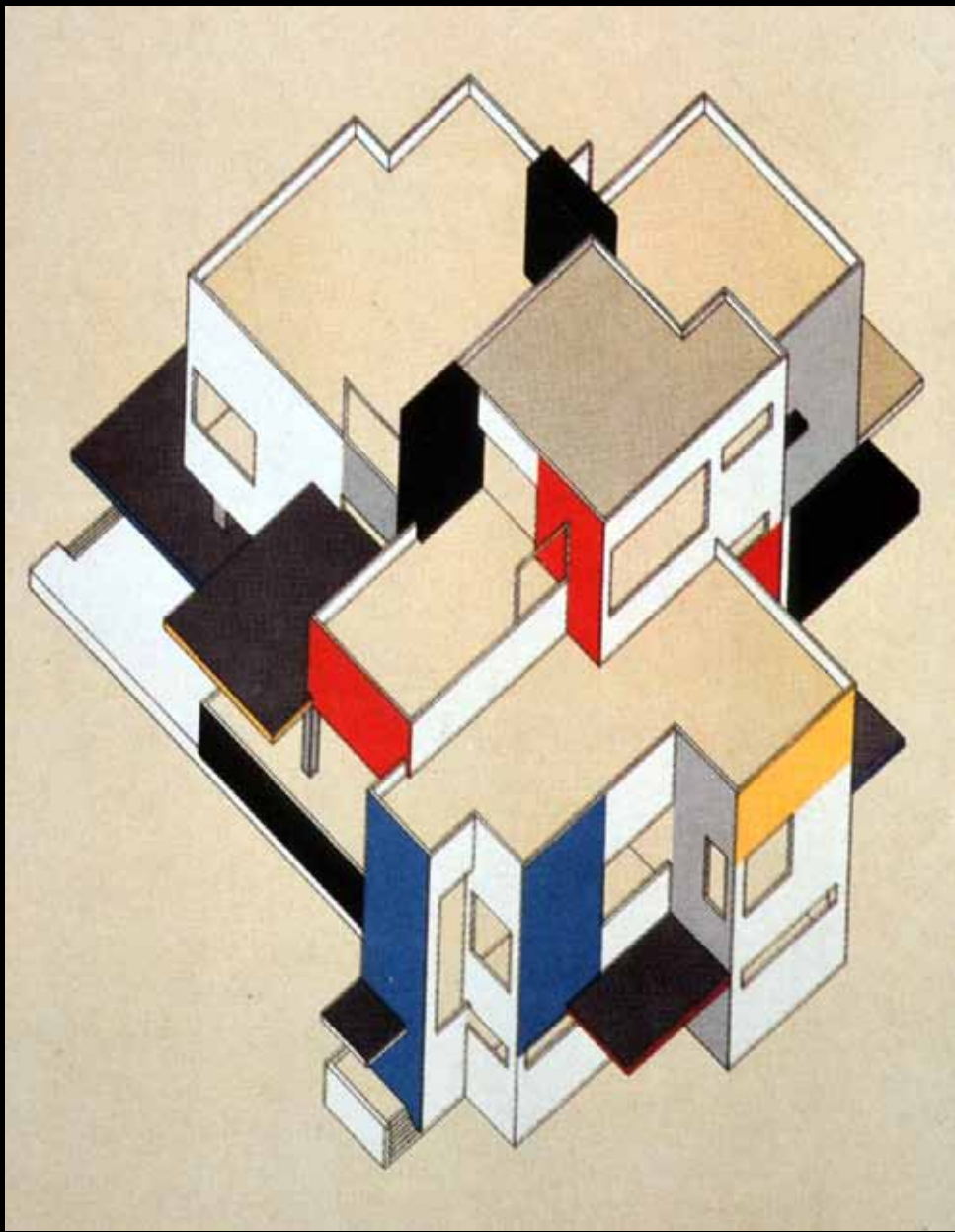

THEO VAN DOESBURG. DER STIJL.

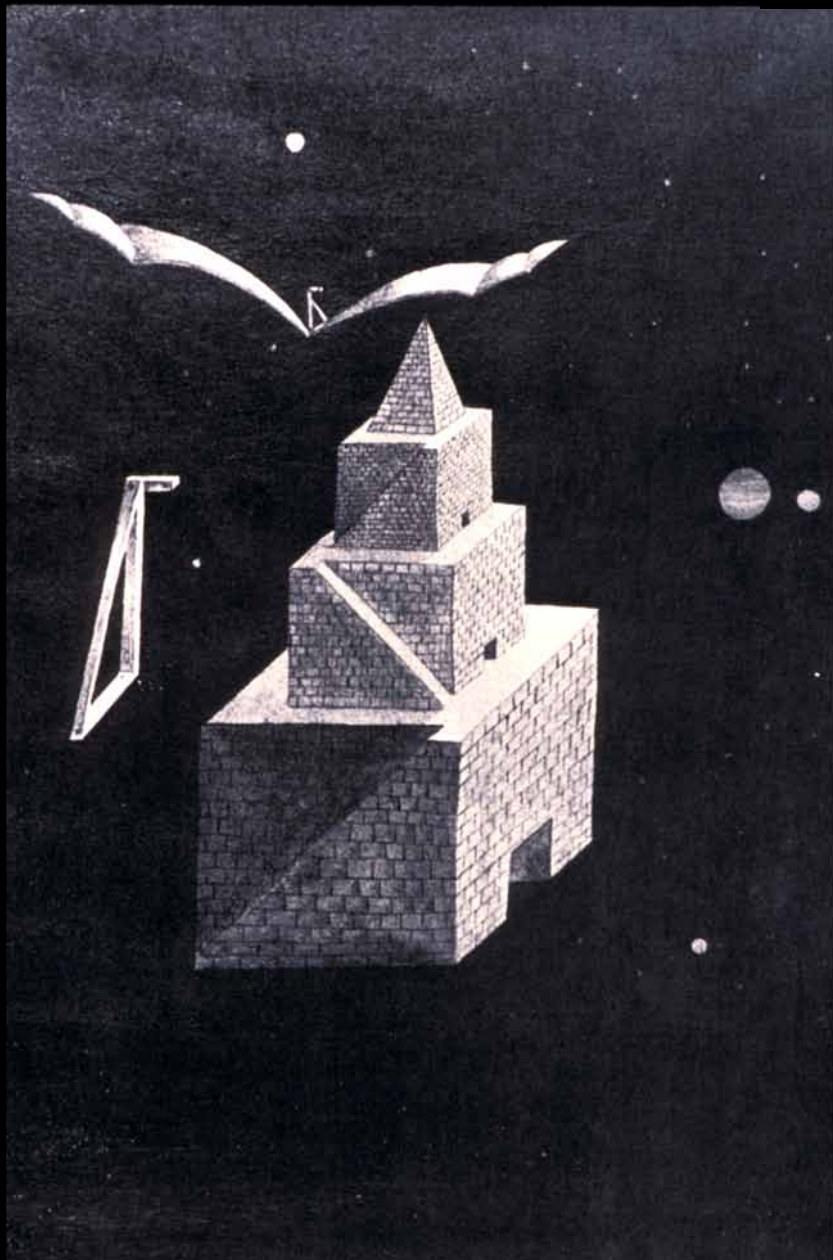

MASSIMO SCOLARI

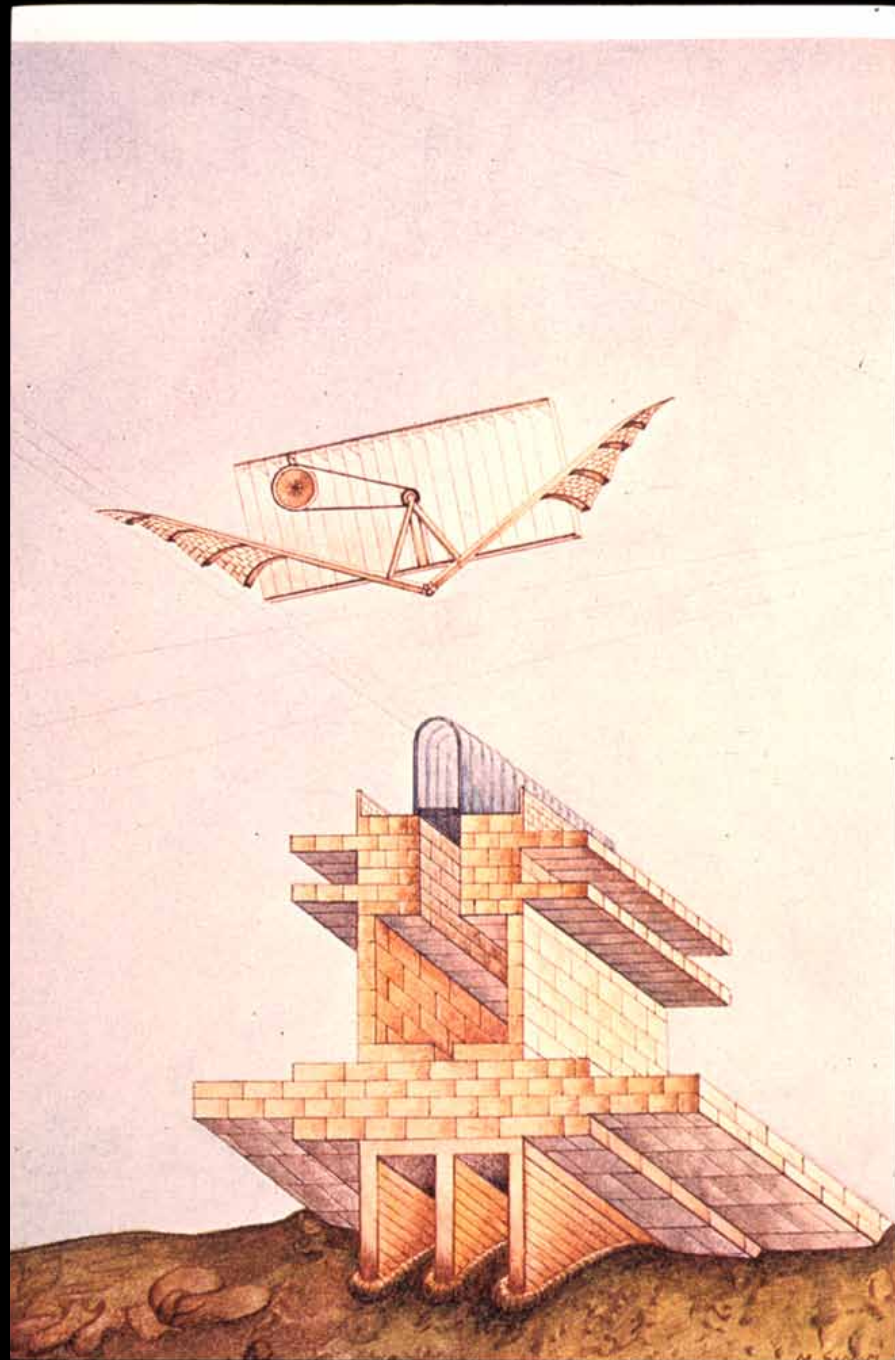

Daniel Libeskind:
Collage Rebus II, 1970.
Axonometrie/Axonometric Crystal

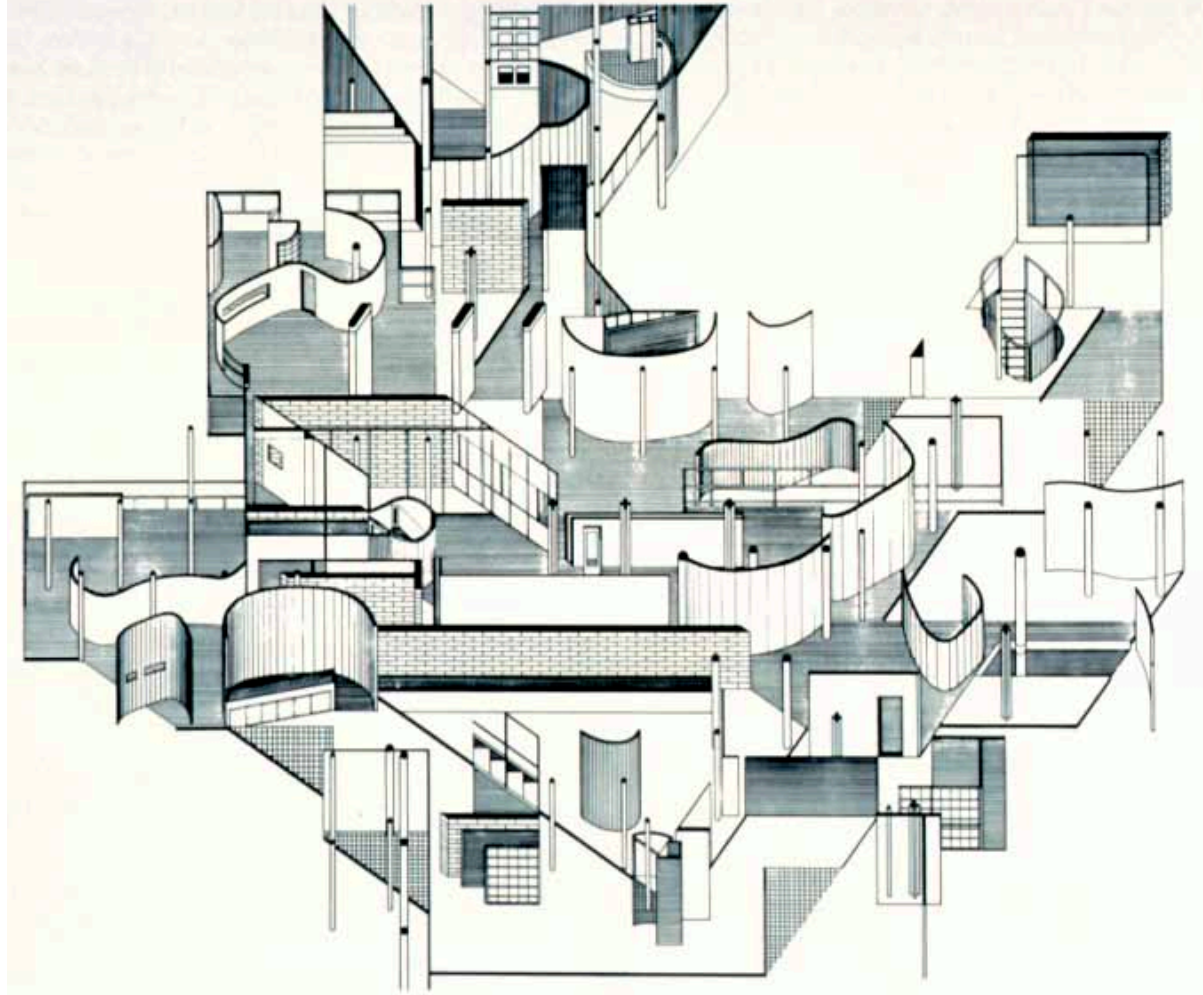

DANIEL LIBESKIND

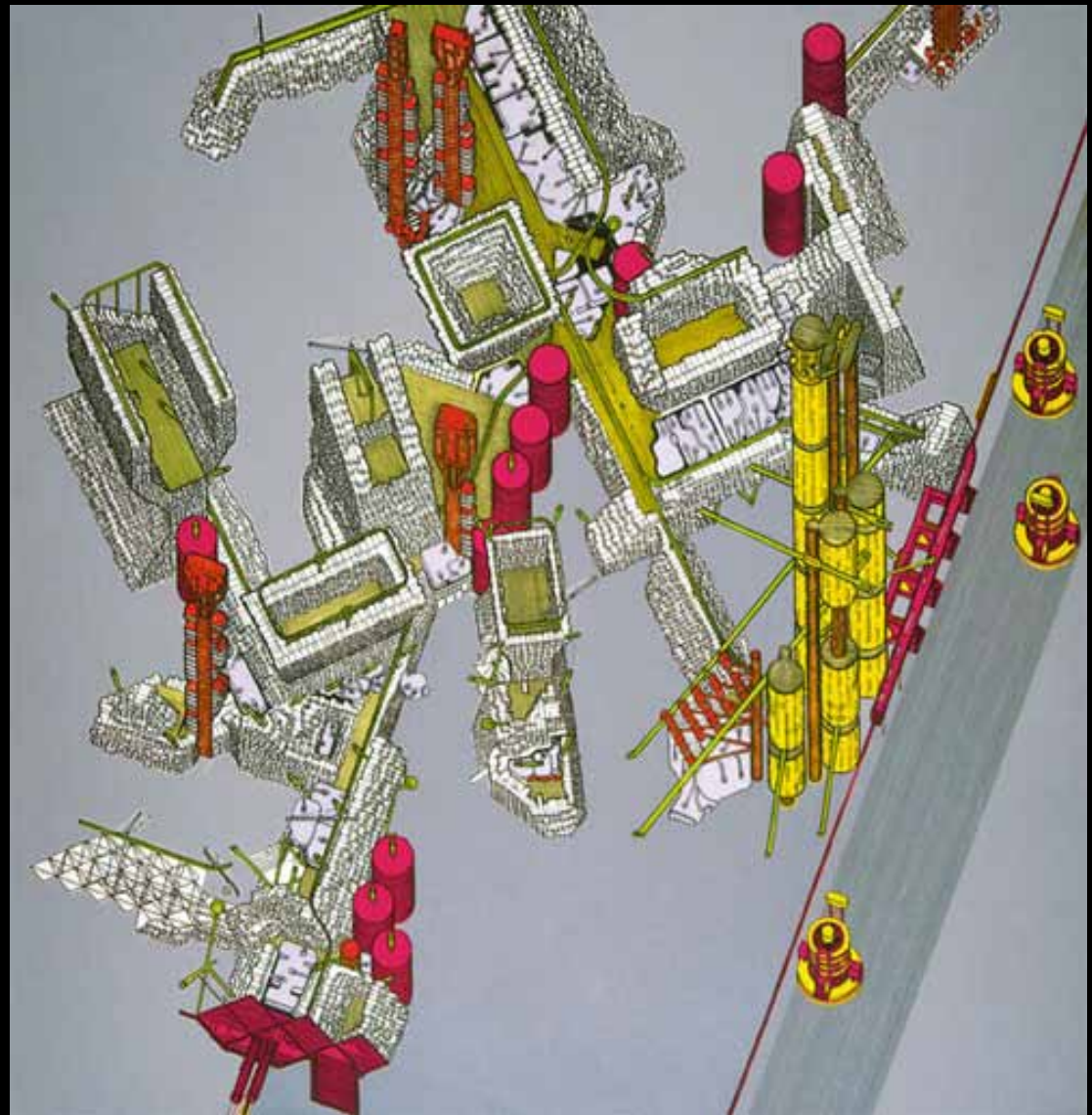

ARCHIGRAM

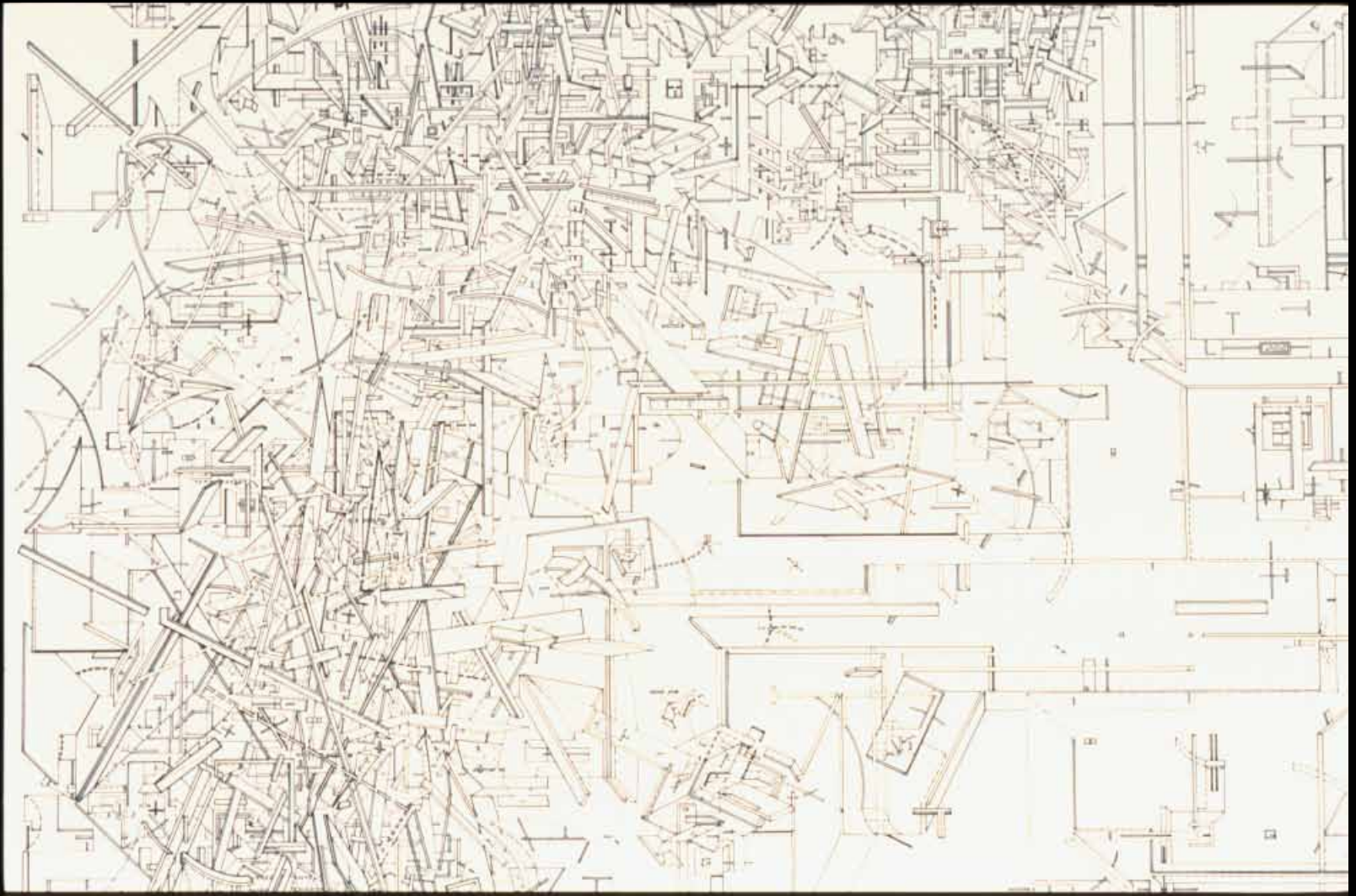

BERNARD TSCHUMI

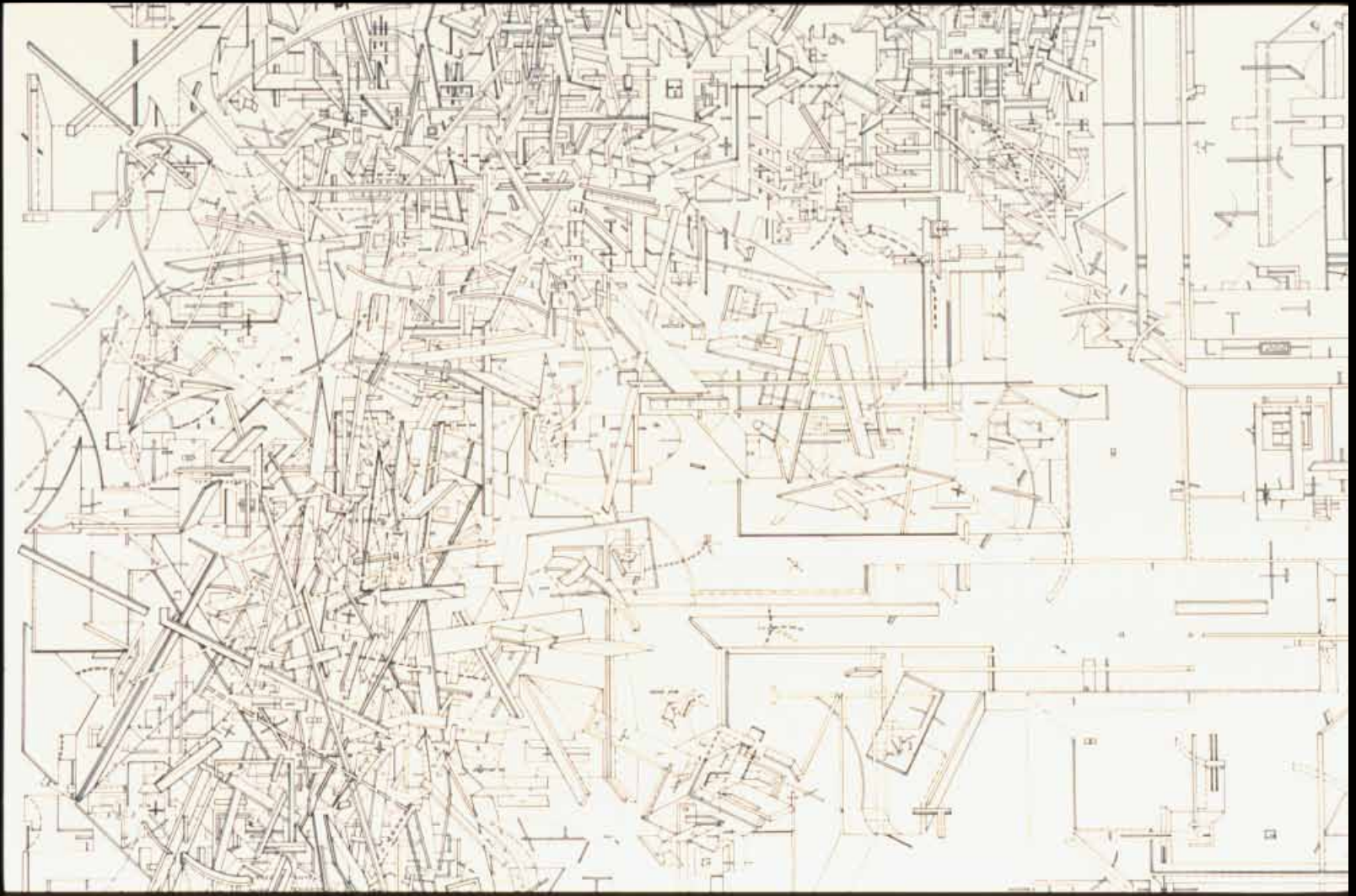

MICROMEGAS.

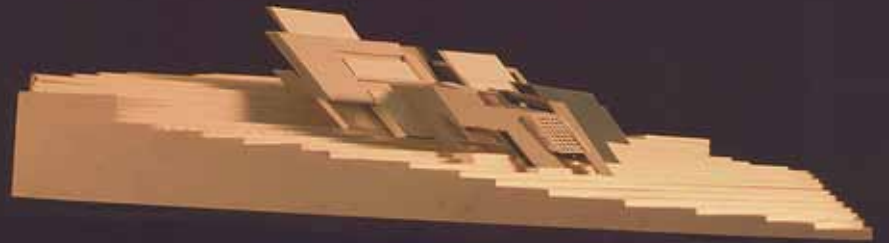
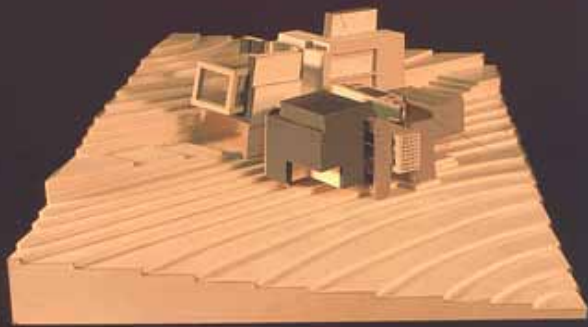

EISENMAN. HOUSE X.

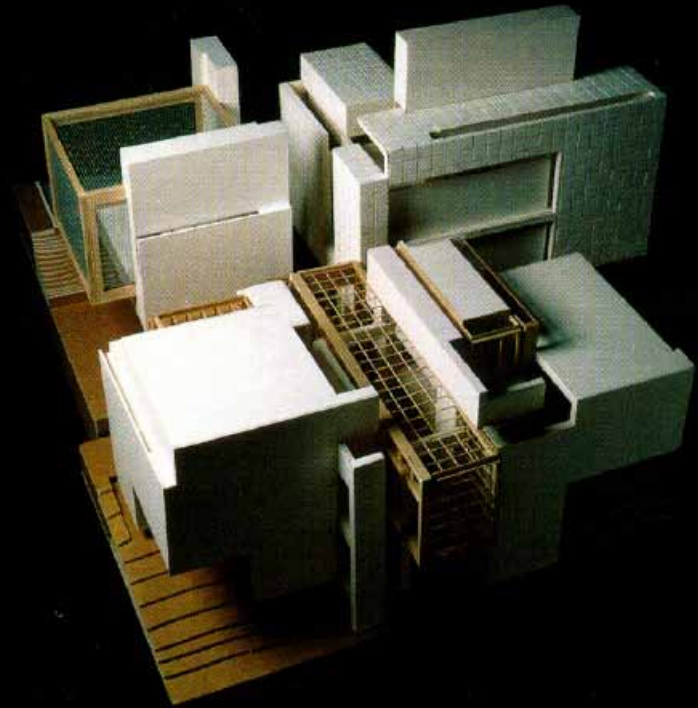
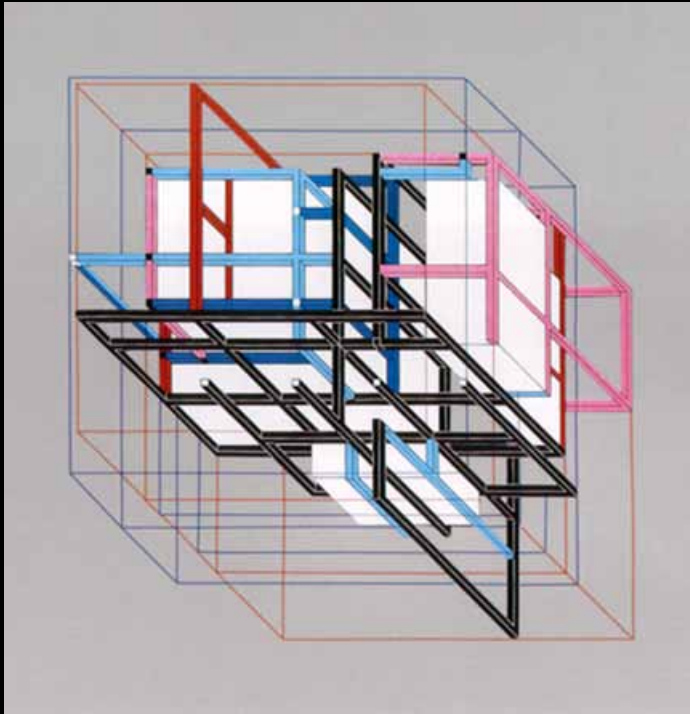

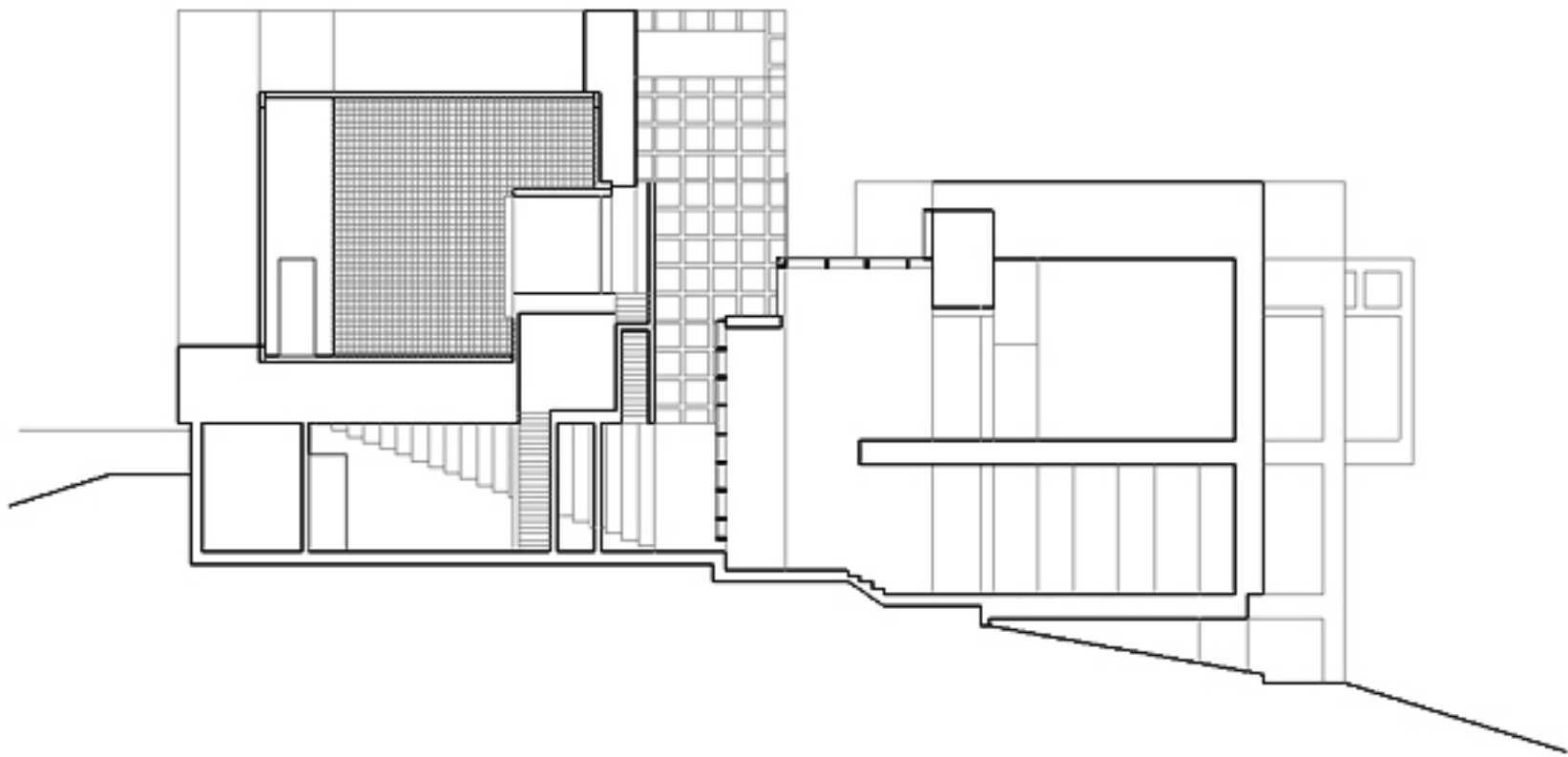

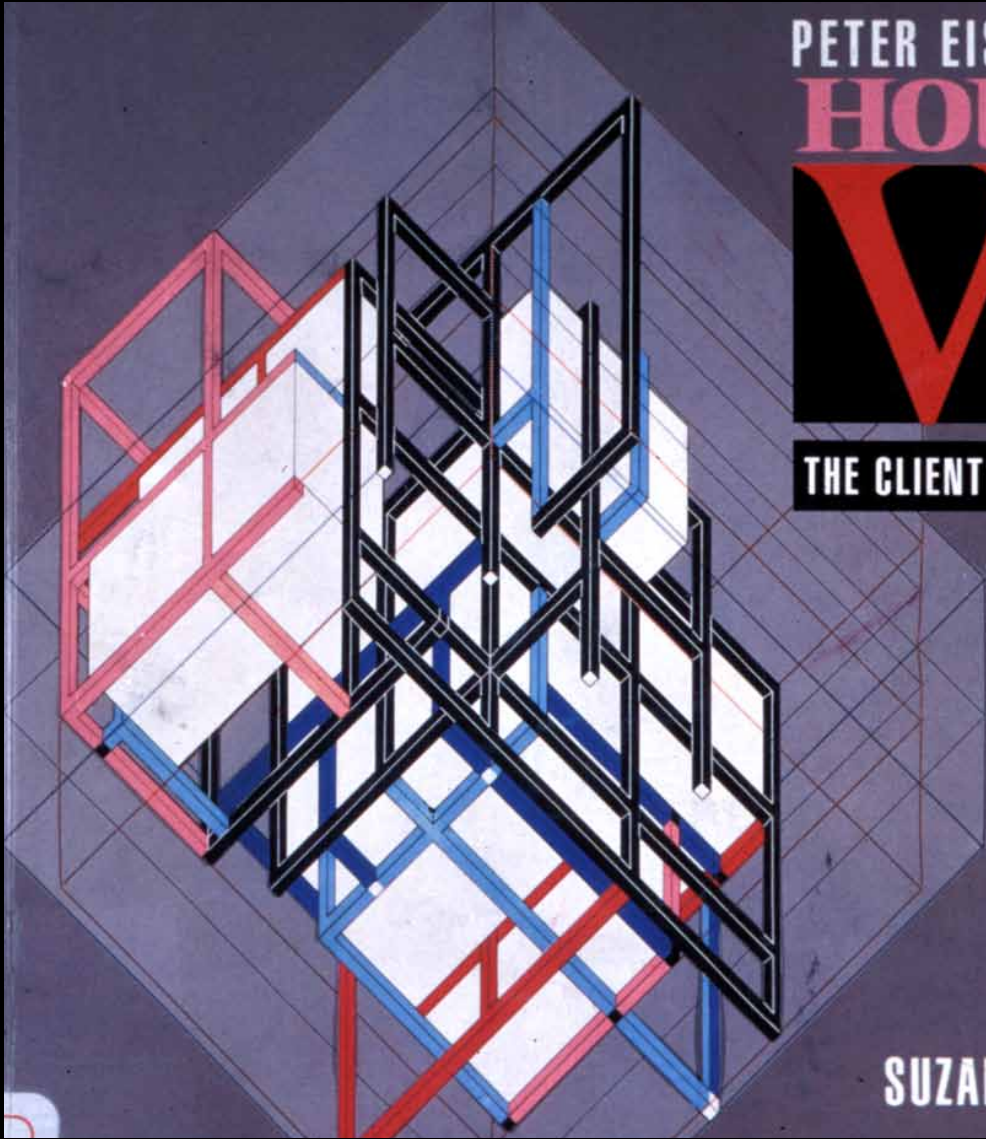

PETER EISENMAN'S
HOUSE

VI

THE CLIENT'S RESPONSE

SUZANNE FRANK

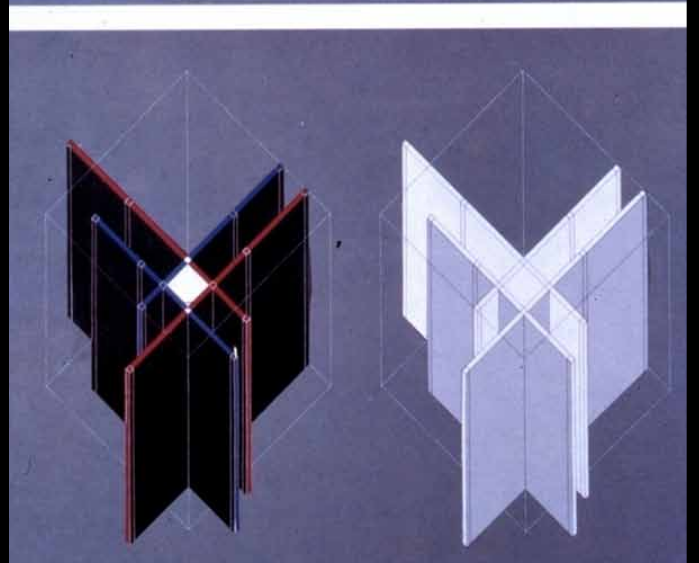
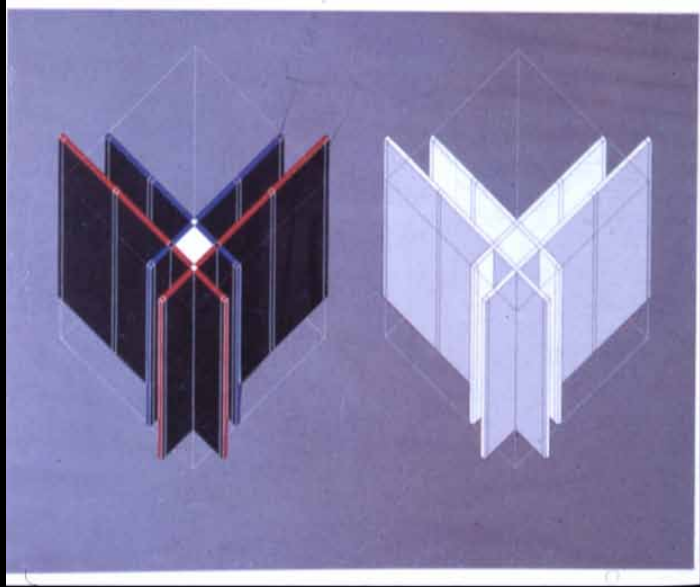
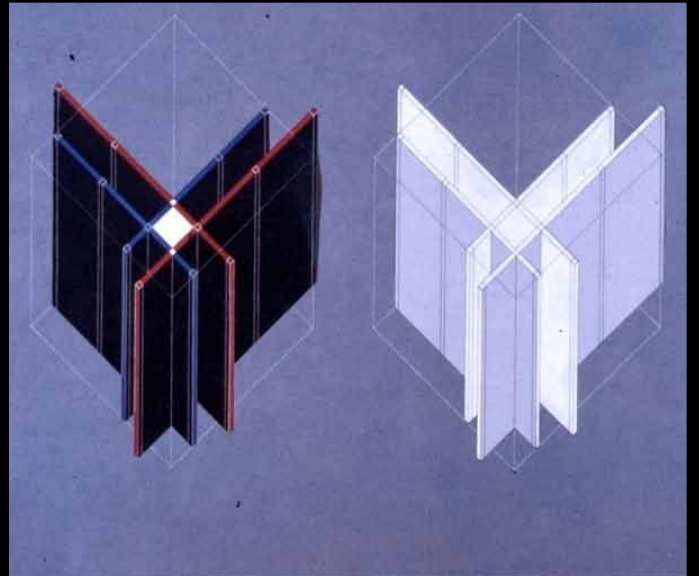
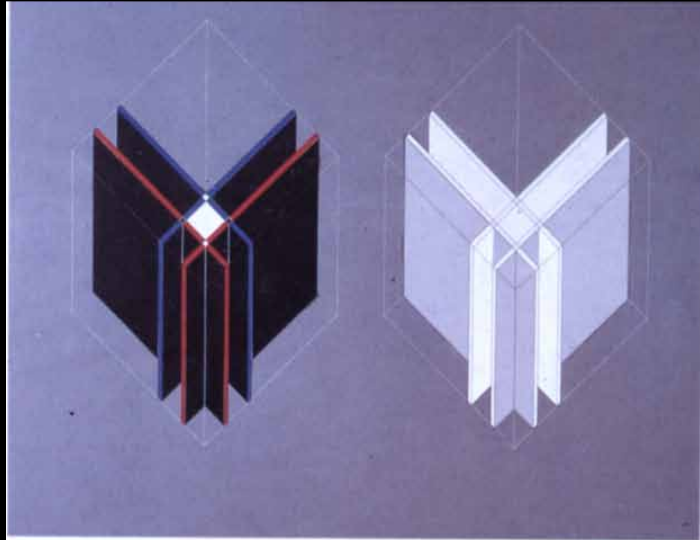

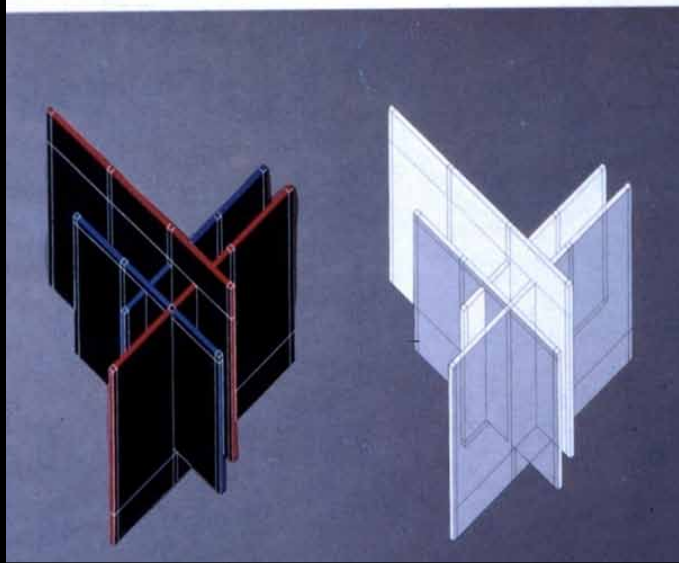
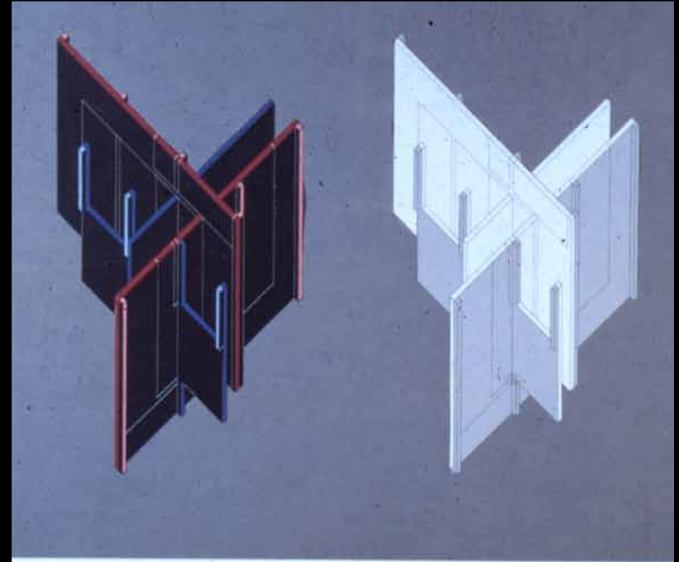
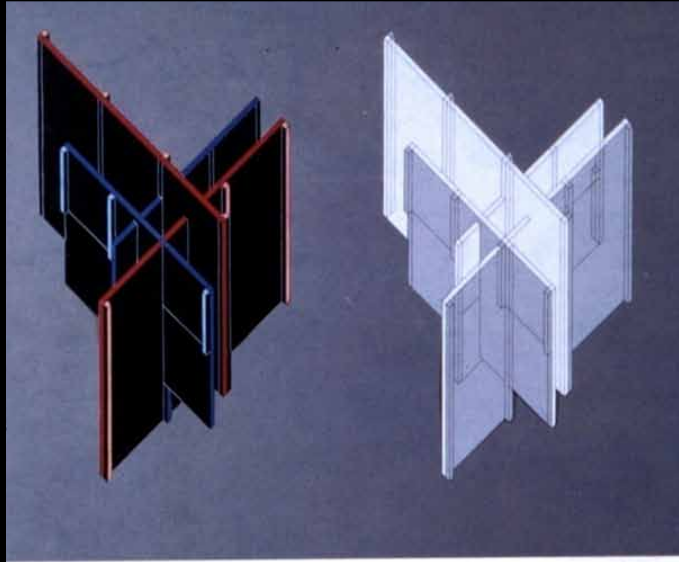

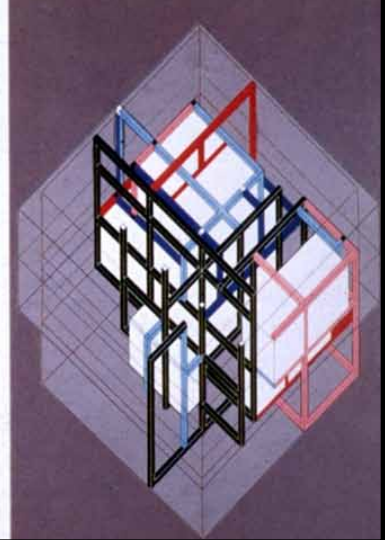
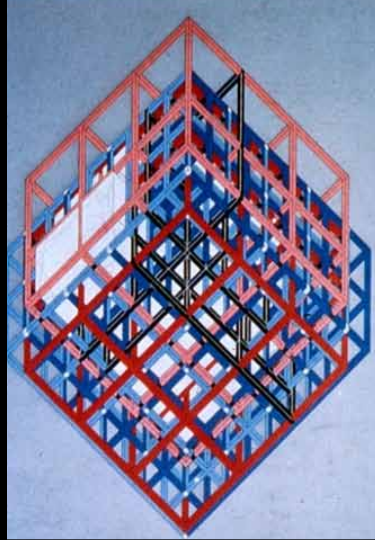
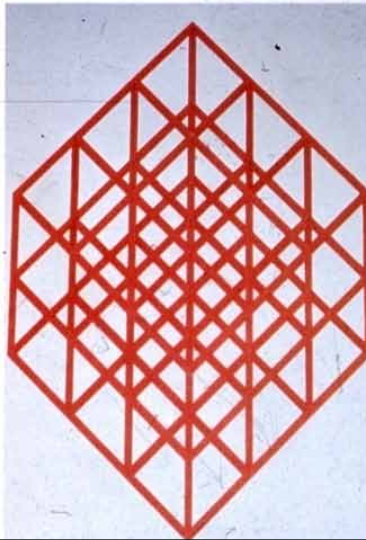
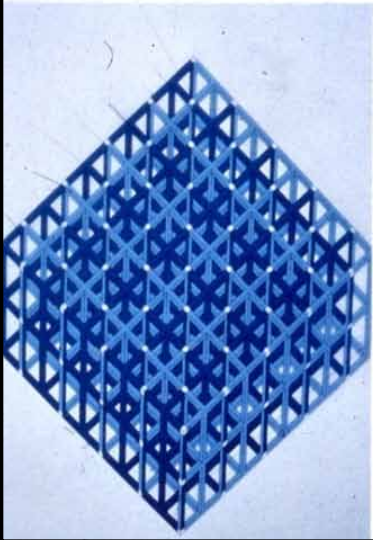
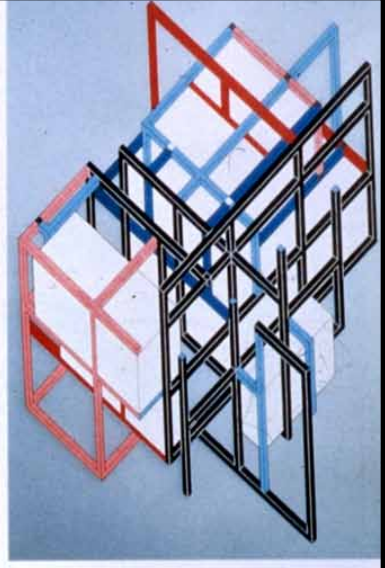
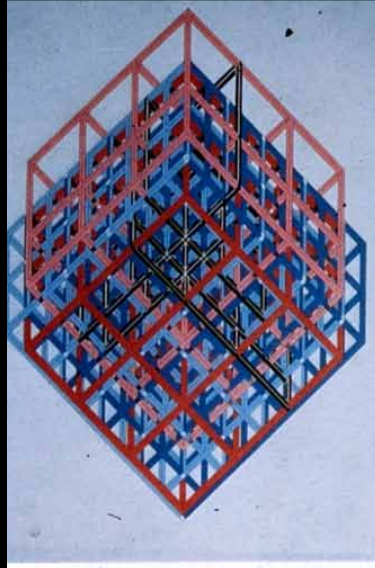
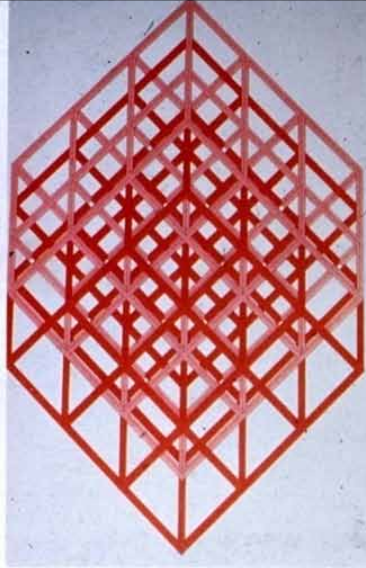
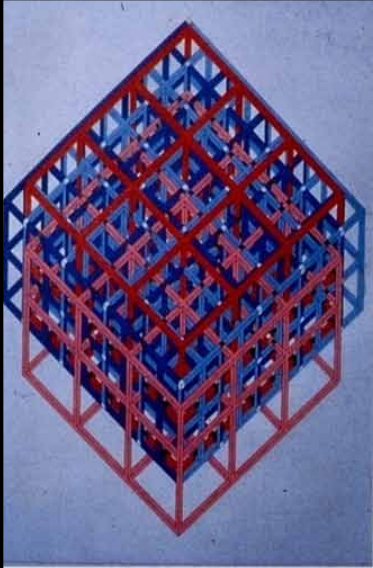



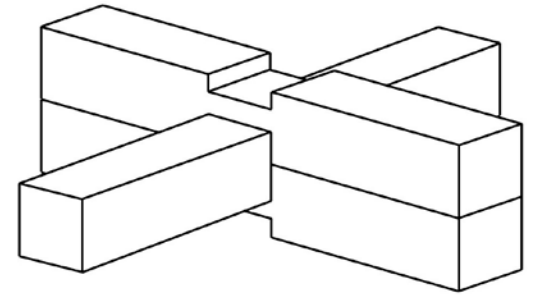
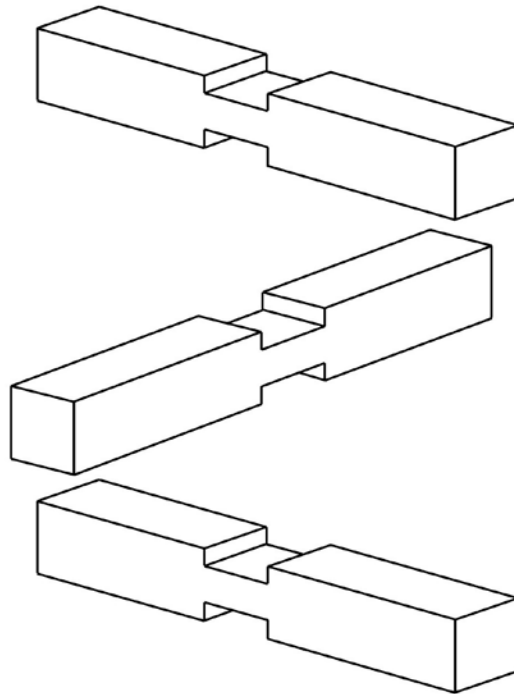
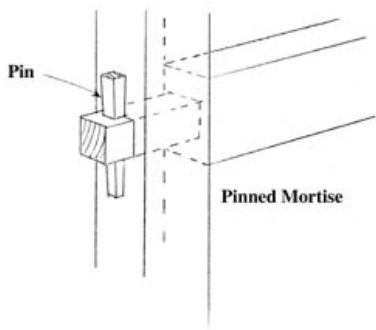
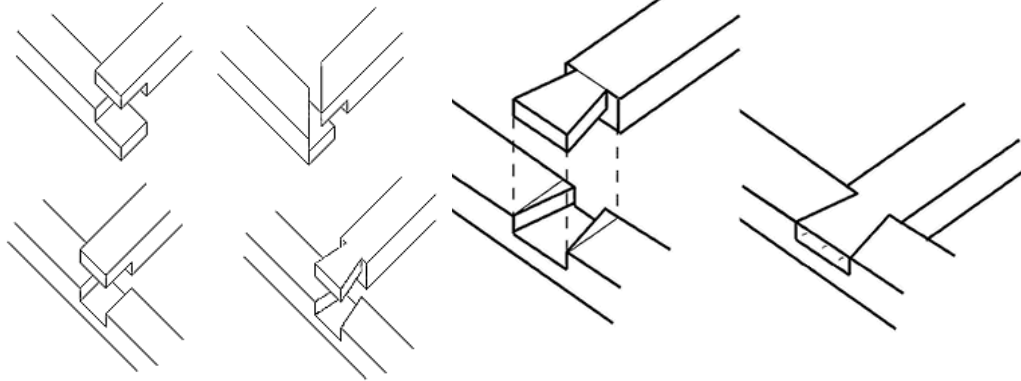
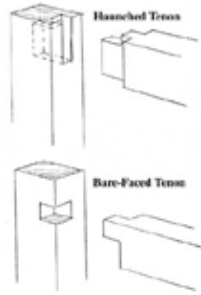
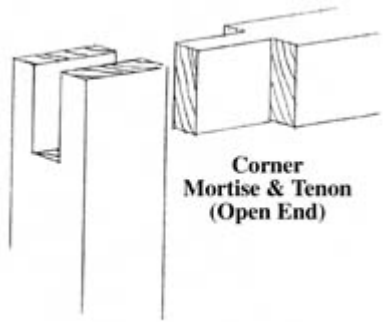

TIMBER JOINTS

LIDEN

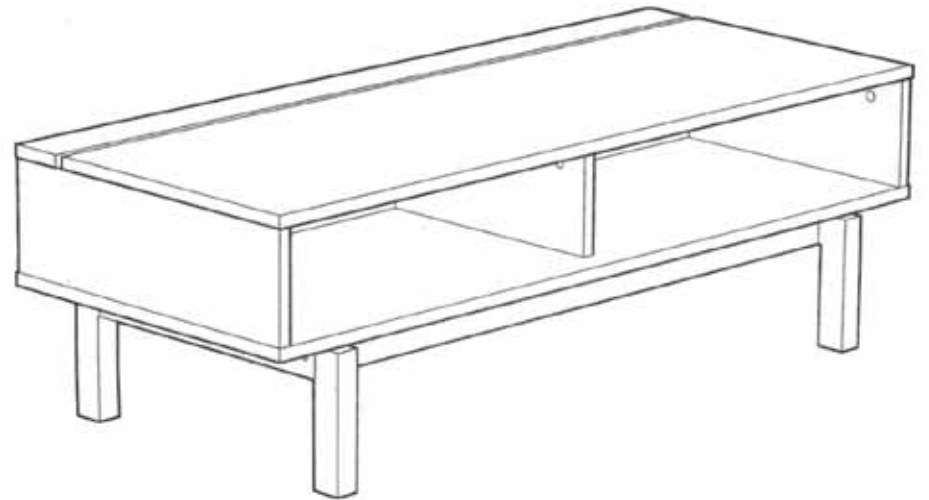

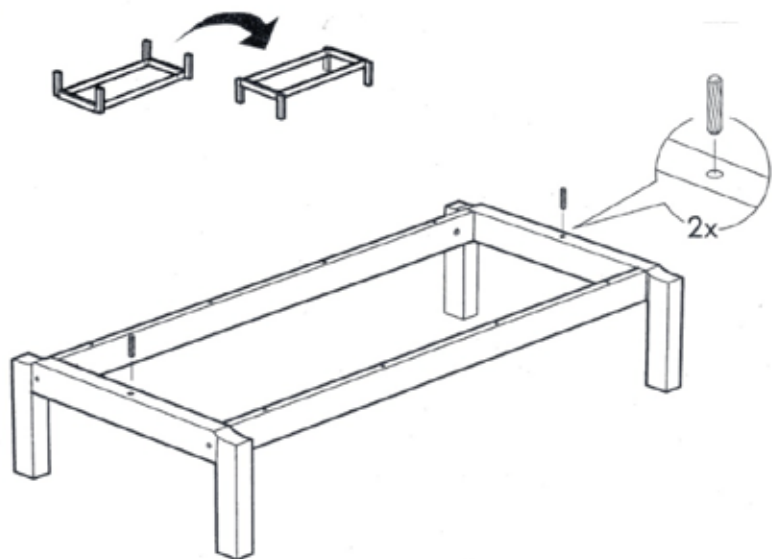
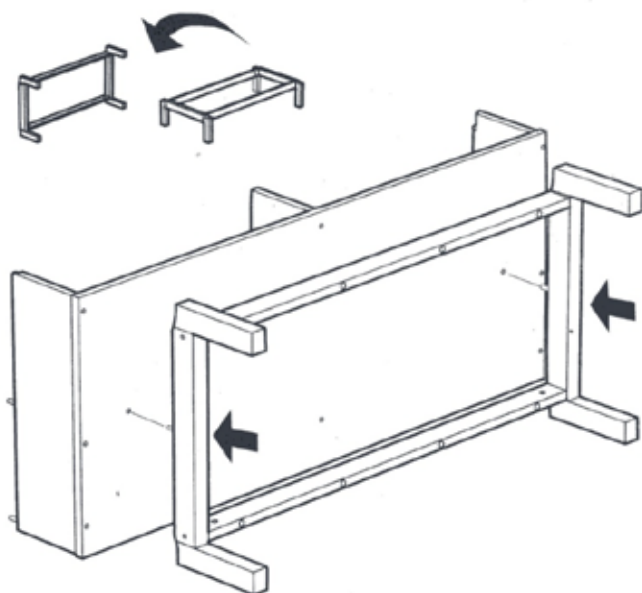
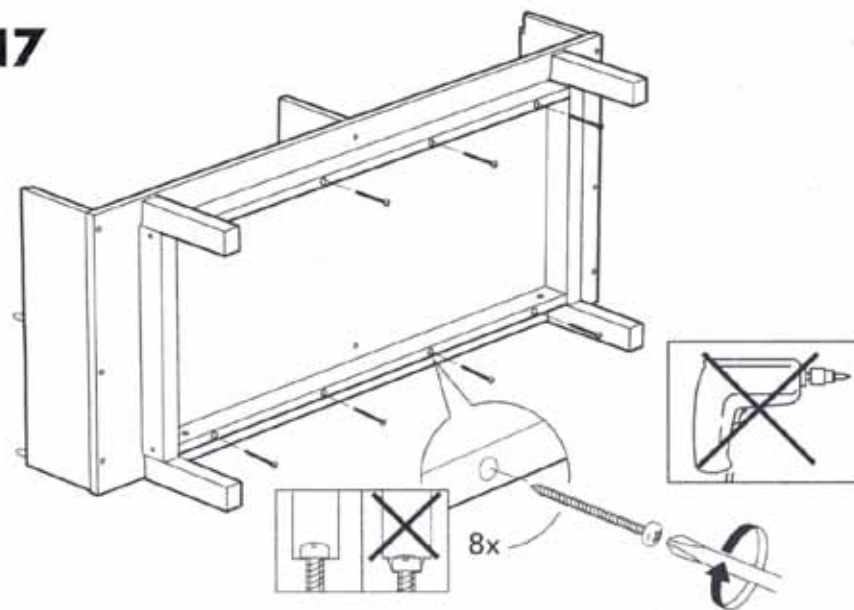
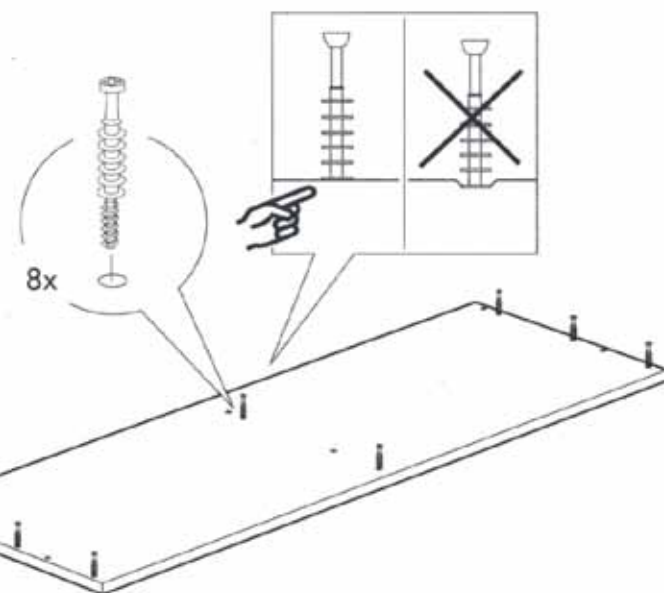
15**16****17****18**

23

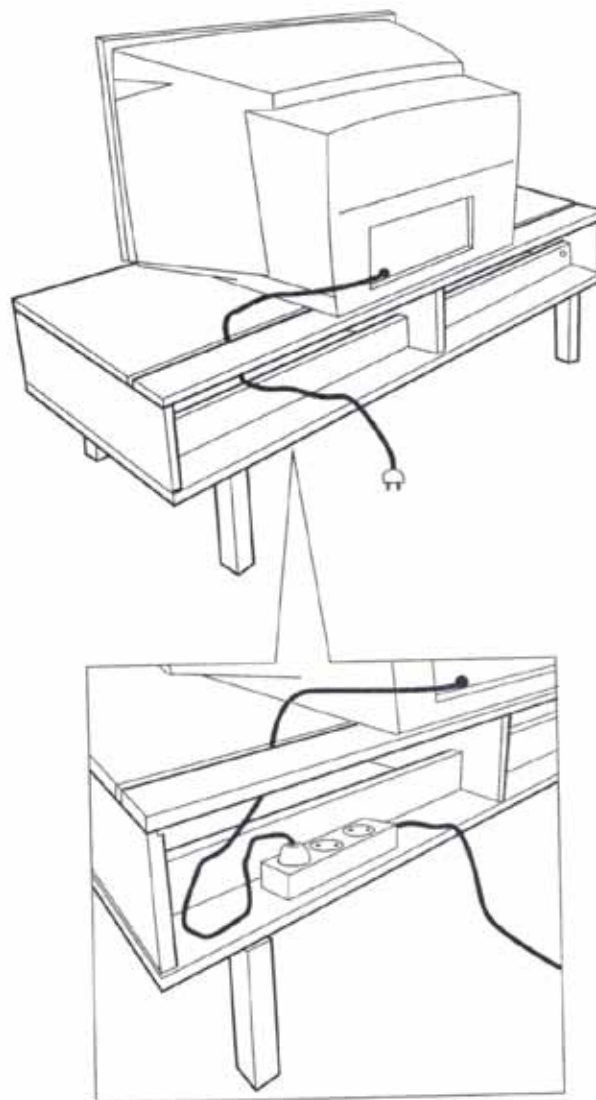



101350

31x

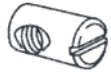

100514

4x

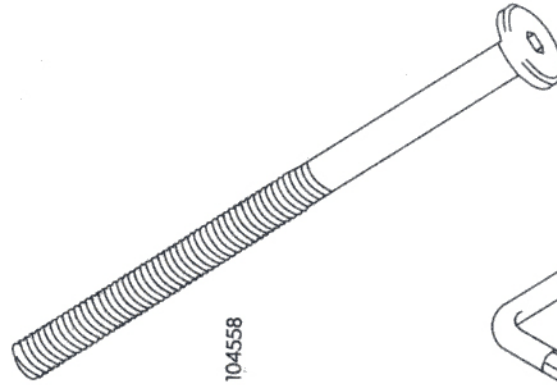

104558

4x

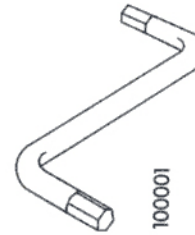

100001

1x



109569

8x



110504

10x



103430

10x



100214

8x



100349

2x

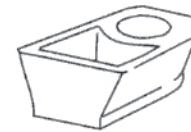

101574

2x

BJÖRKUDDEN

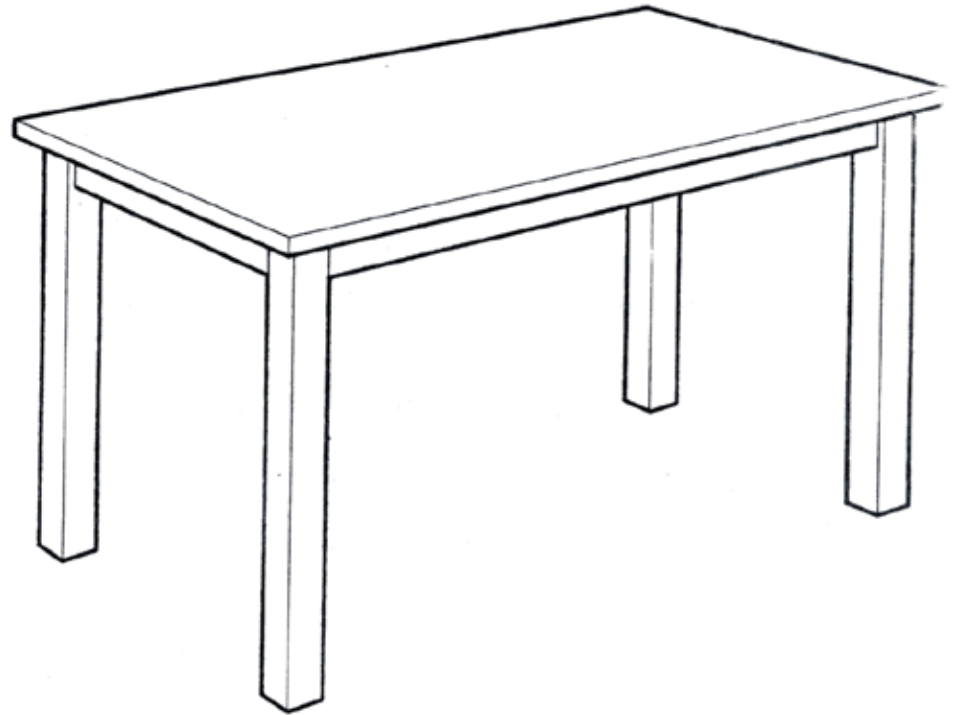



10x



16x

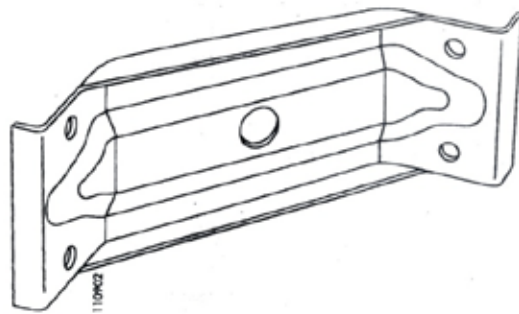

4x

1

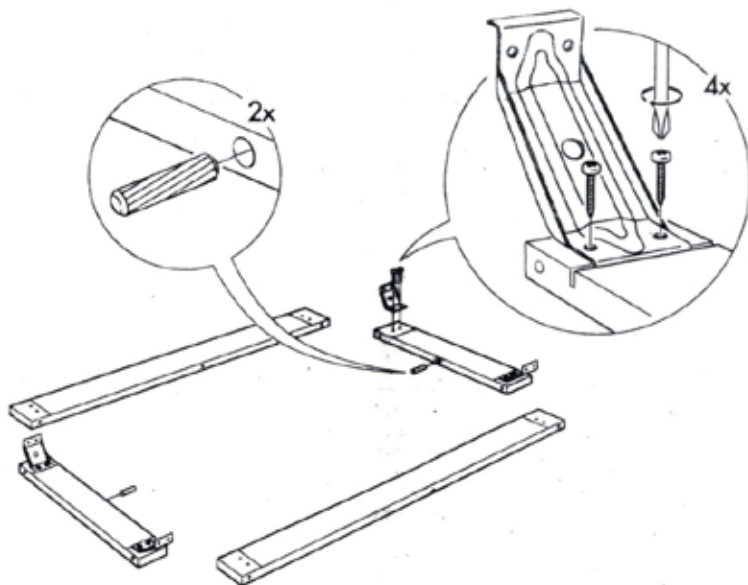

5

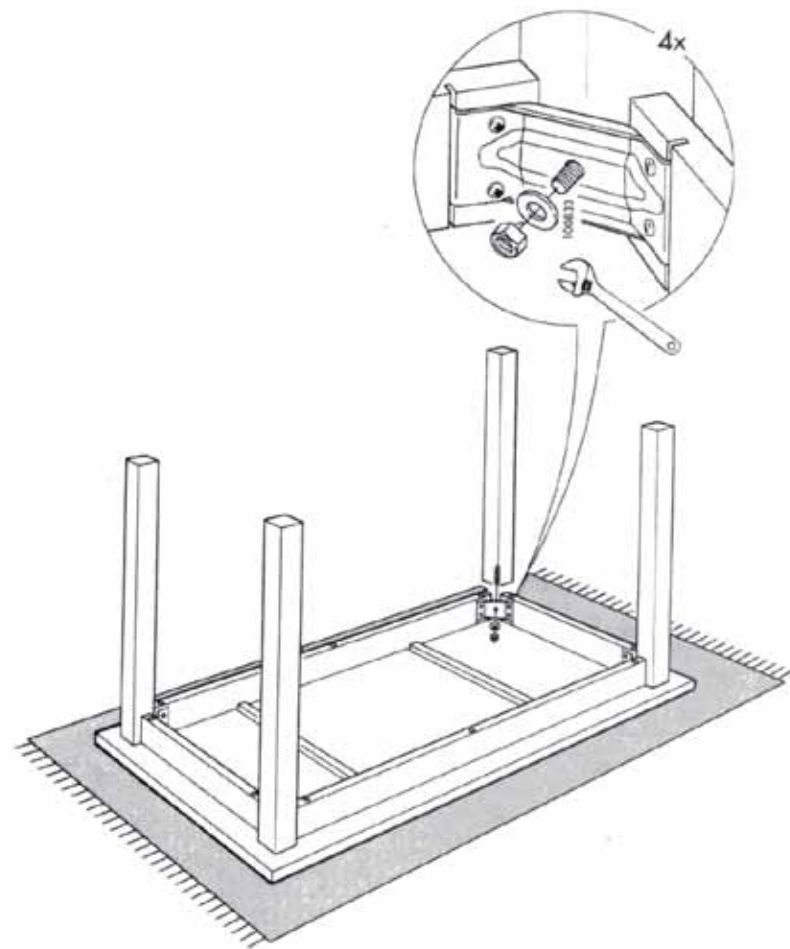

STUDENT WORK

AXONOMETRIC DRAWING

II

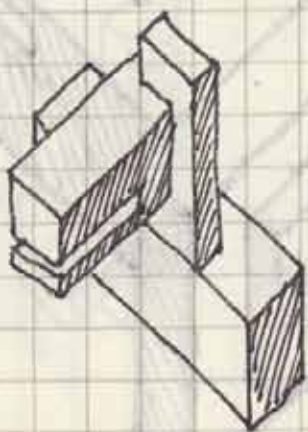
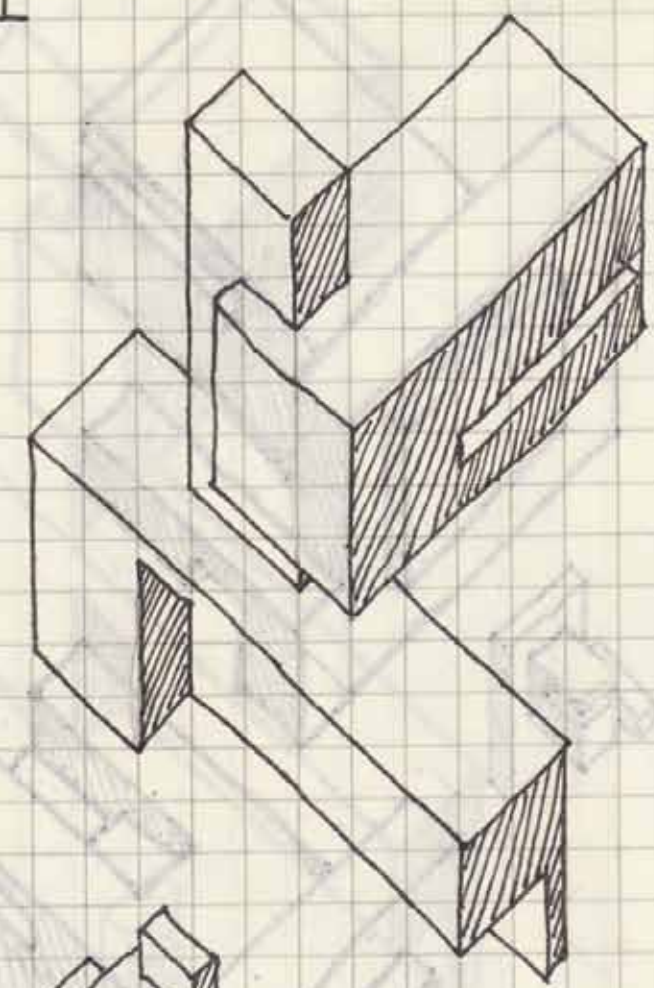

 opposite angle.

III

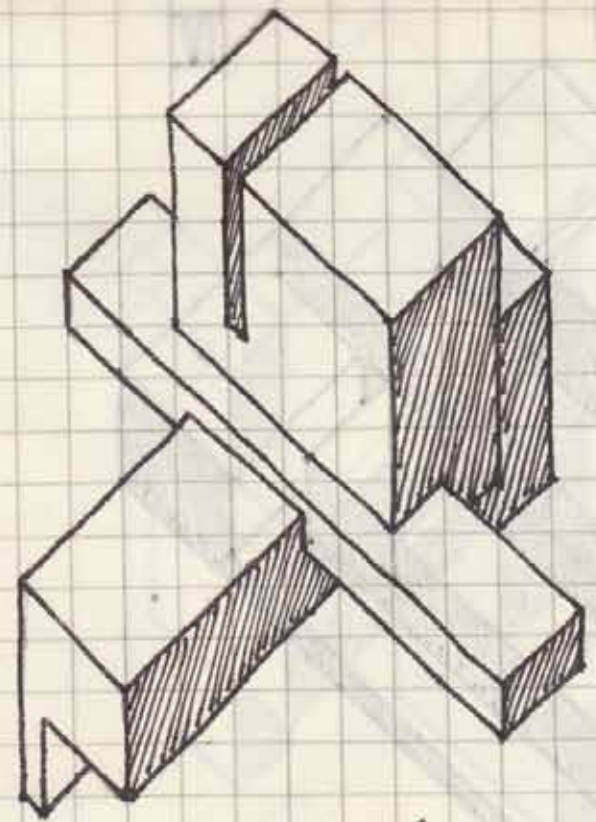

 opposite angle.

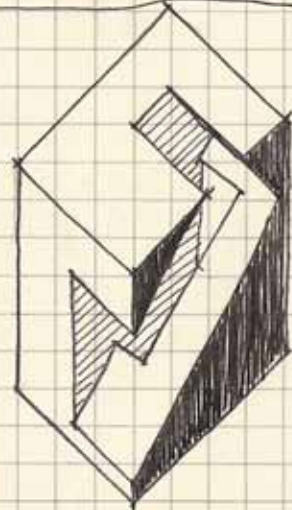
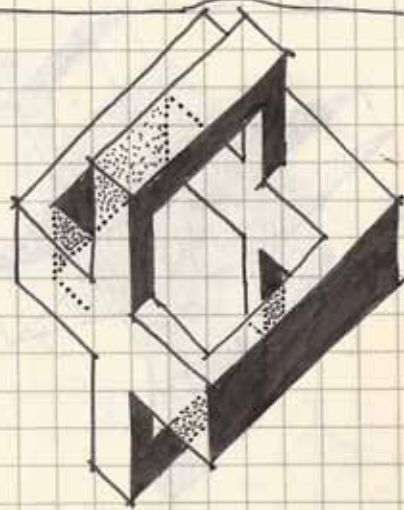
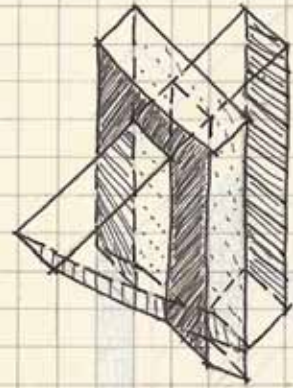

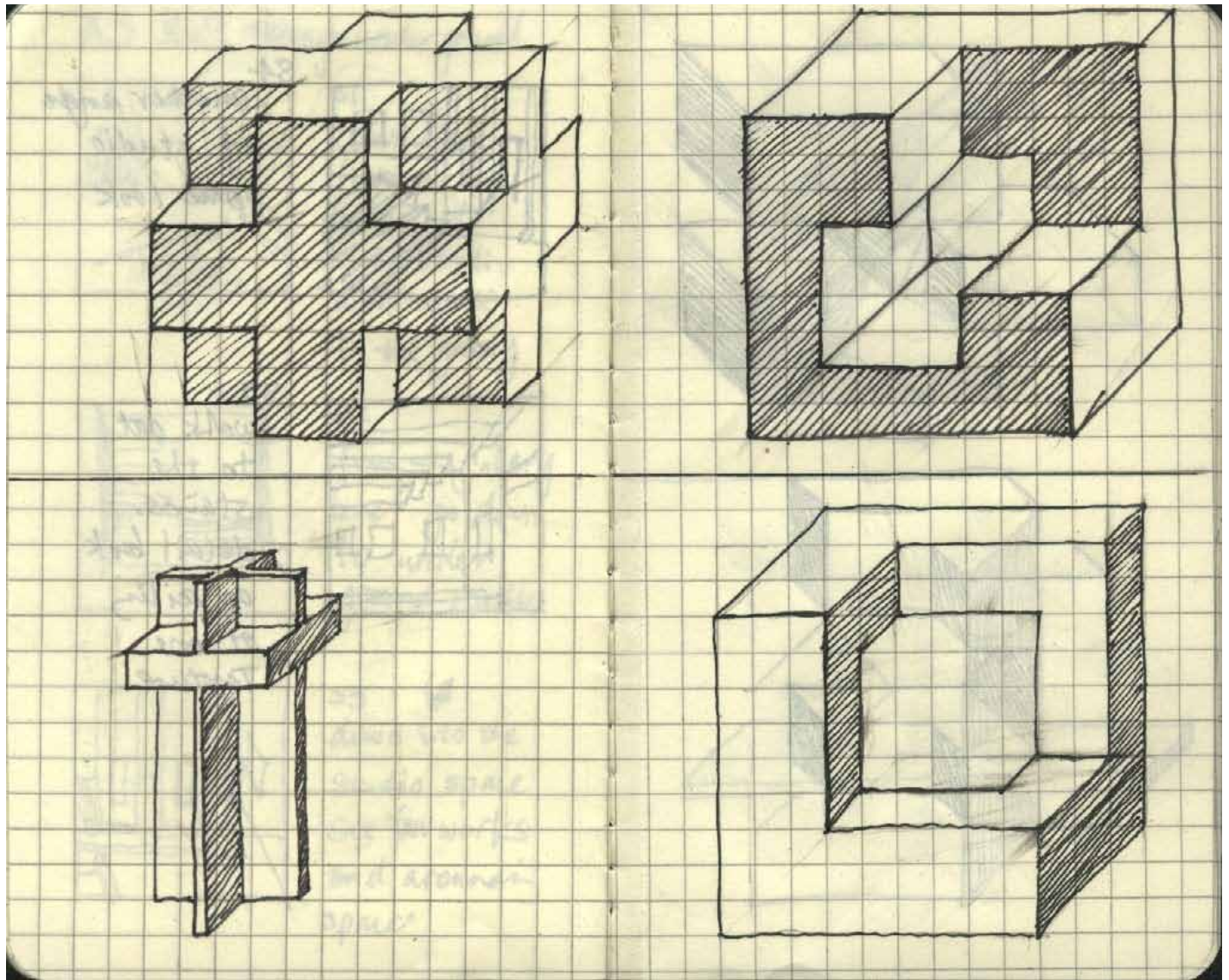

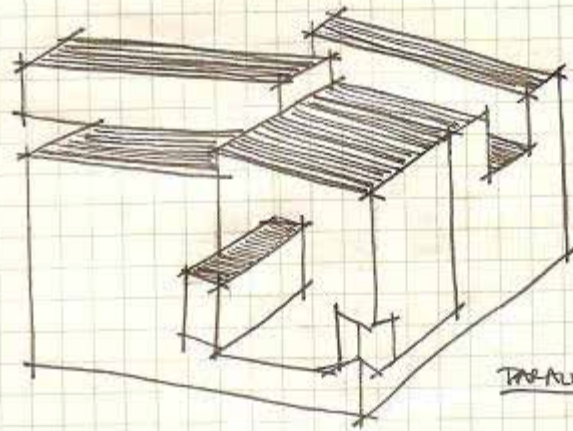

PARALLEL PROJECTION 7

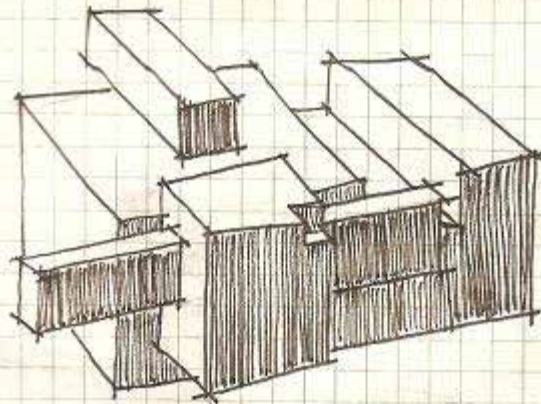

PARALLEL PROJECTION 8

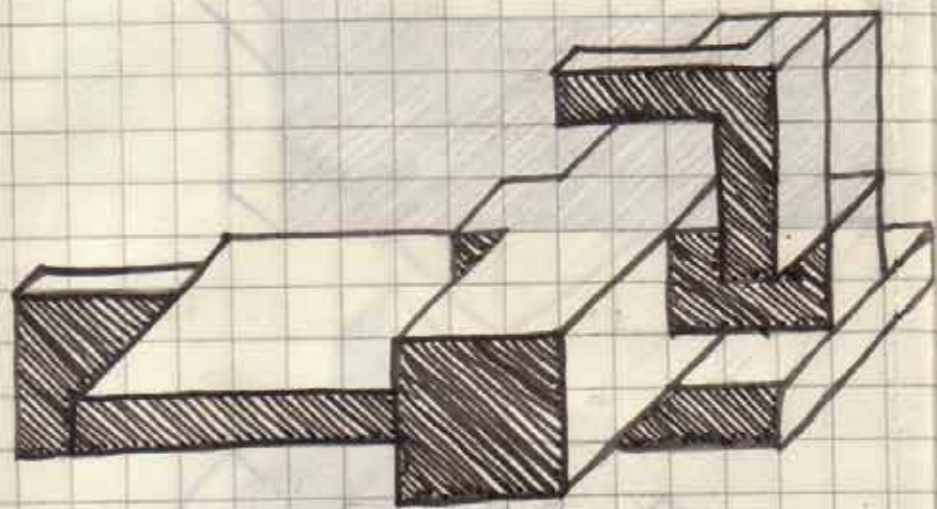
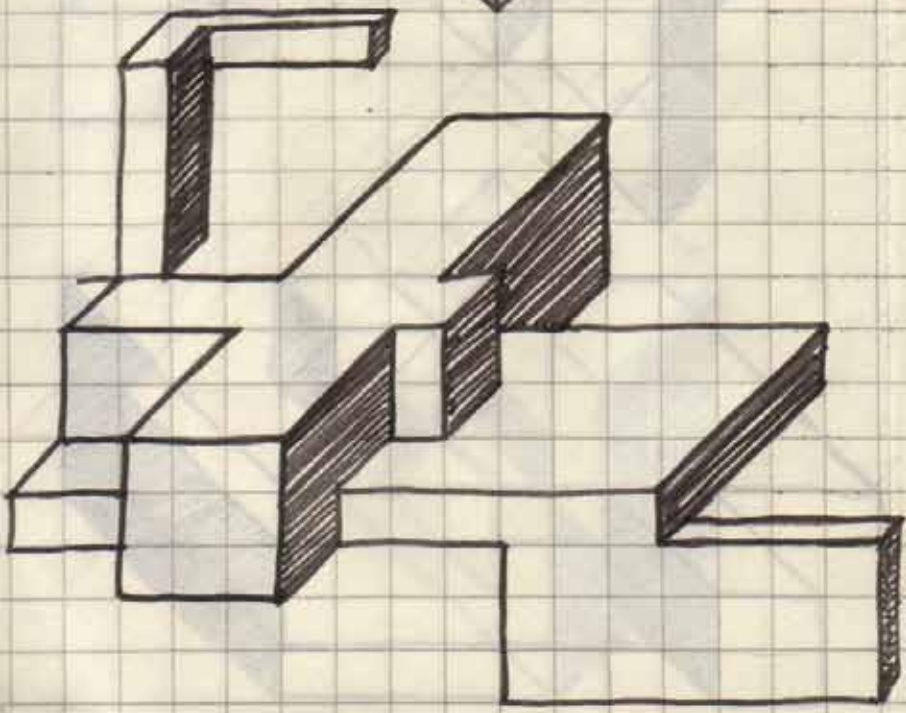
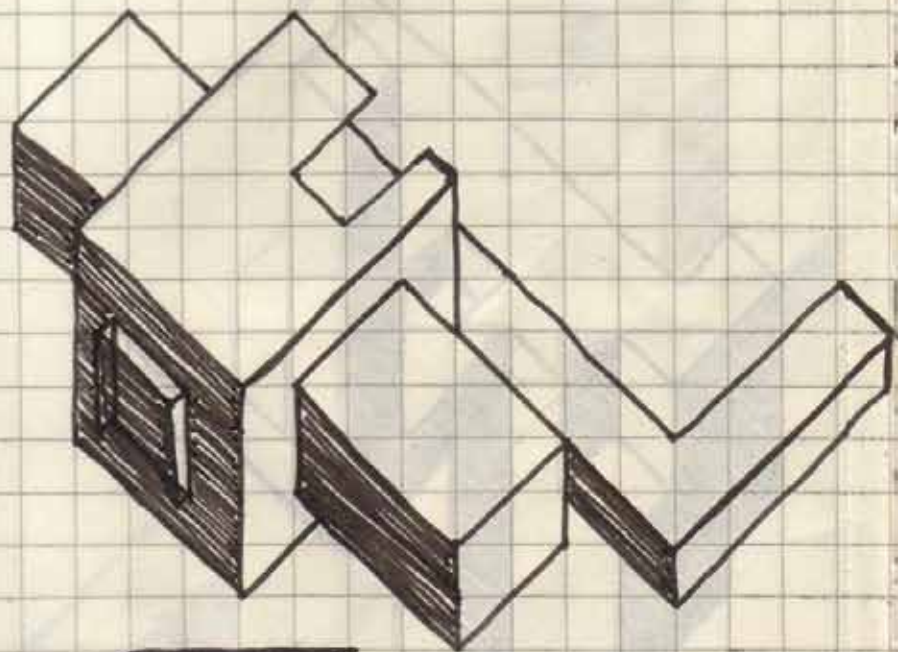

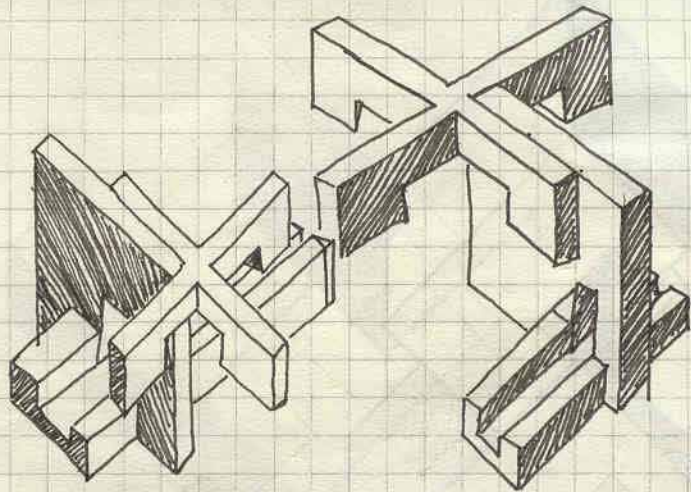

is too simple the answer??

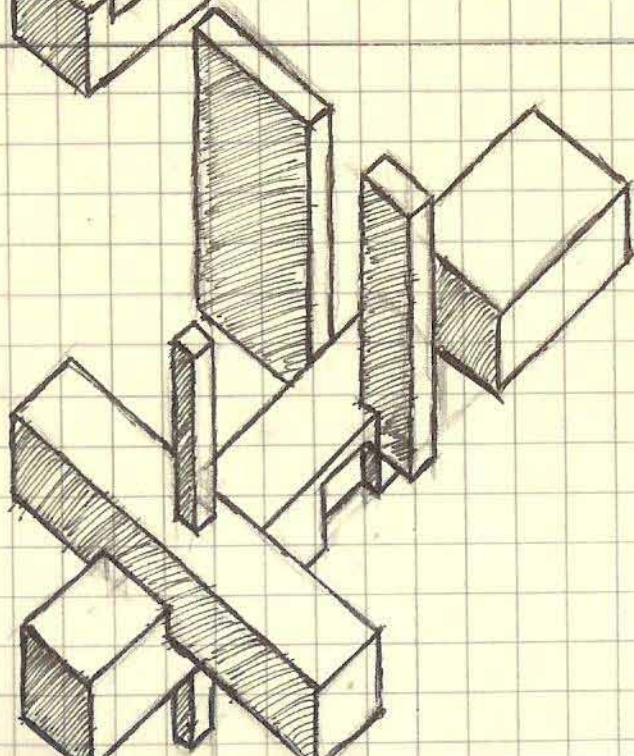
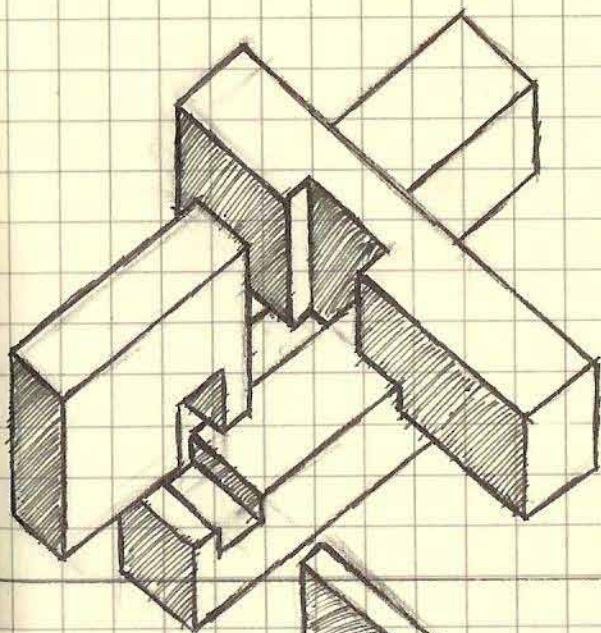
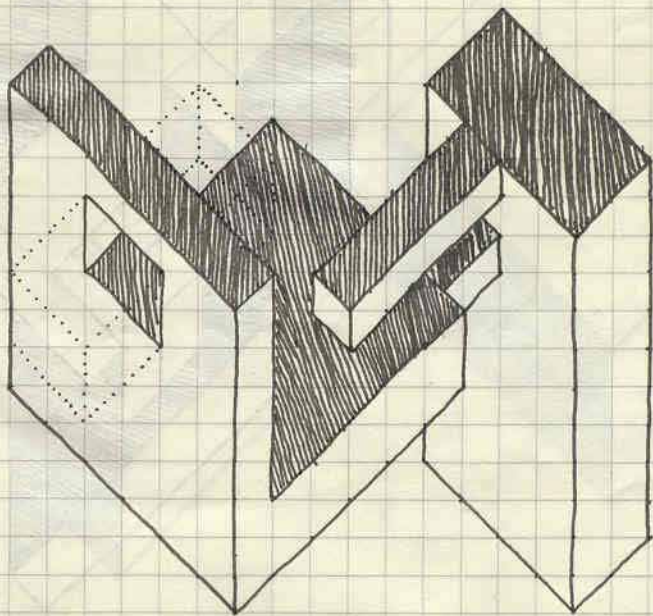

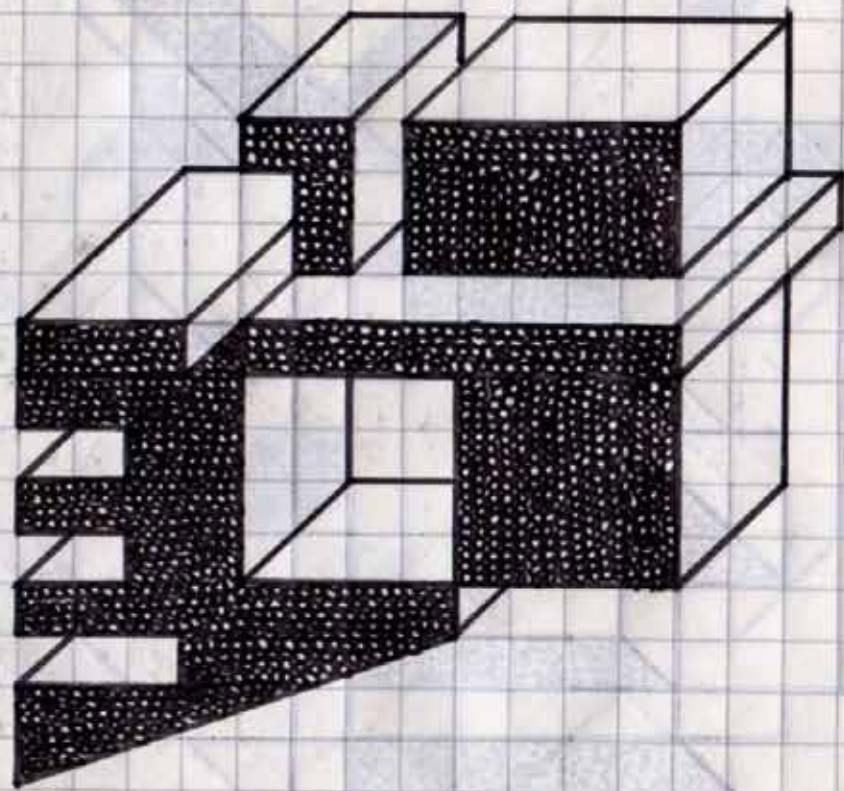
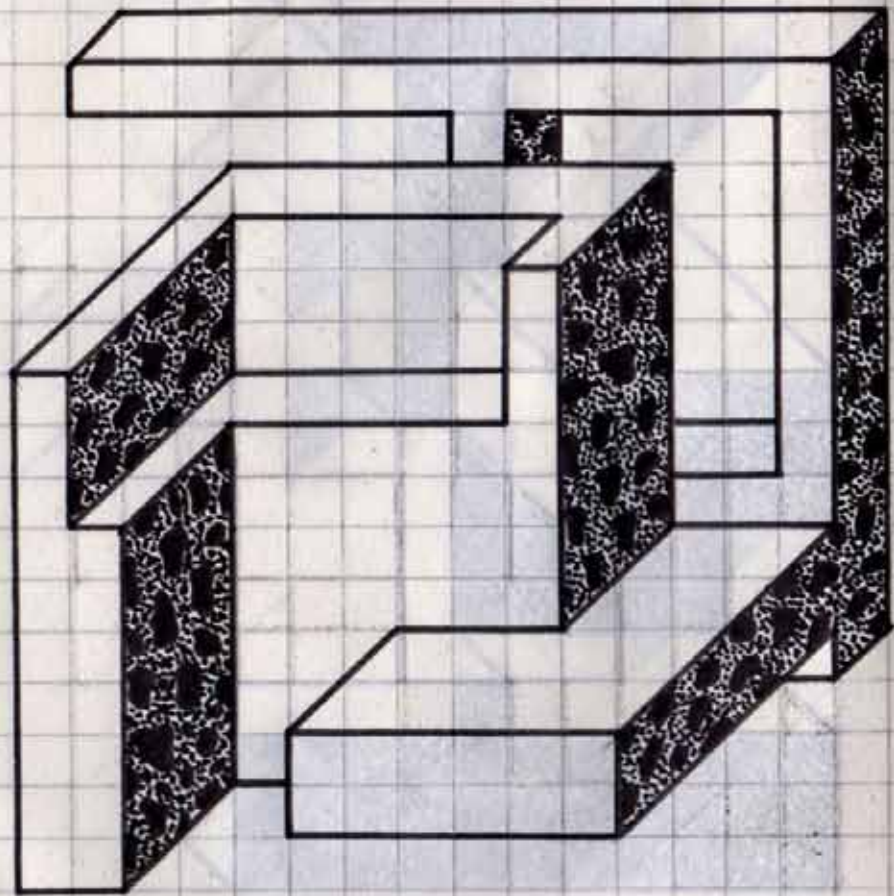

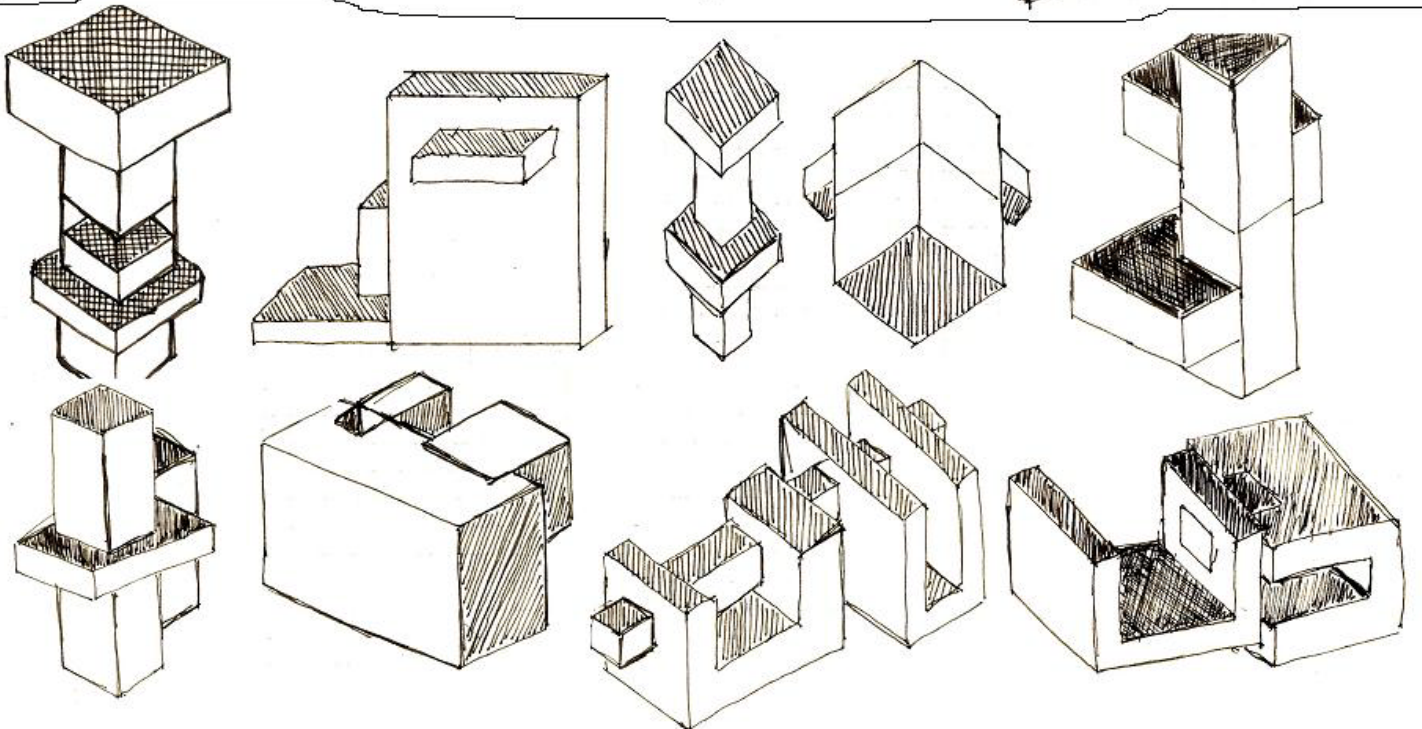
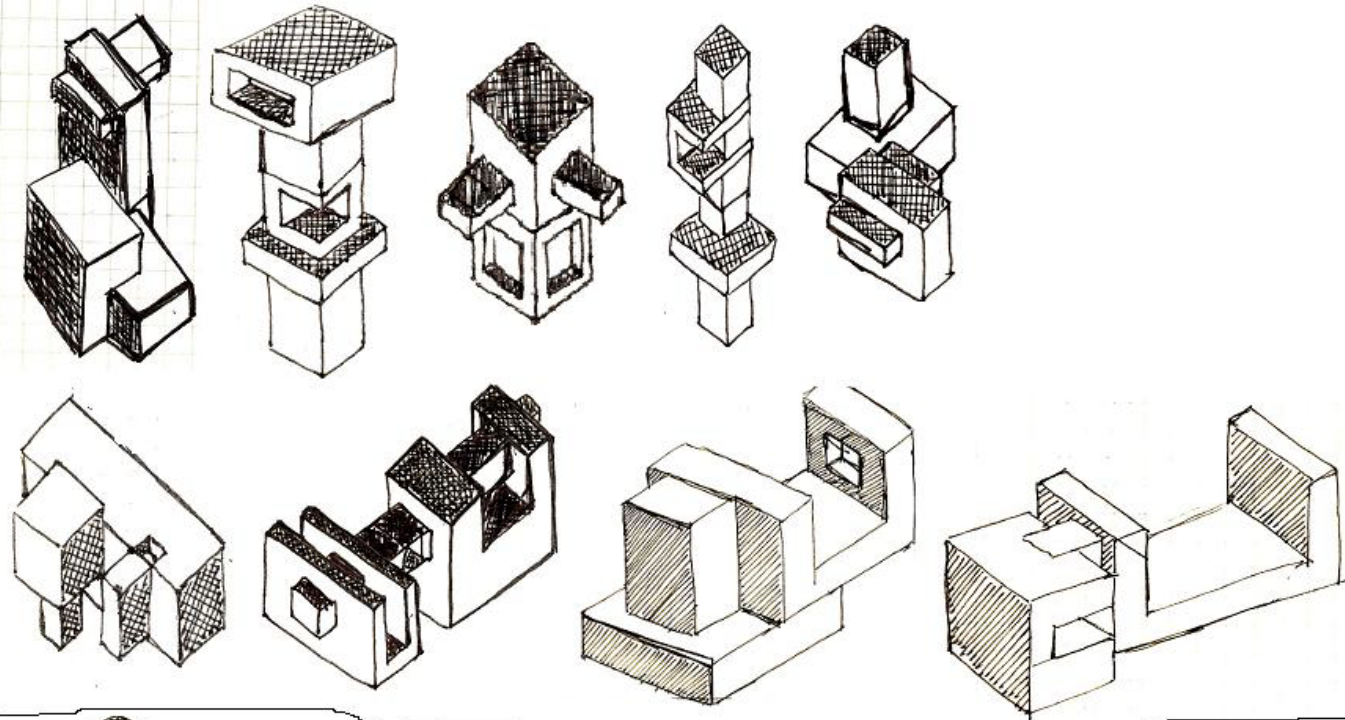

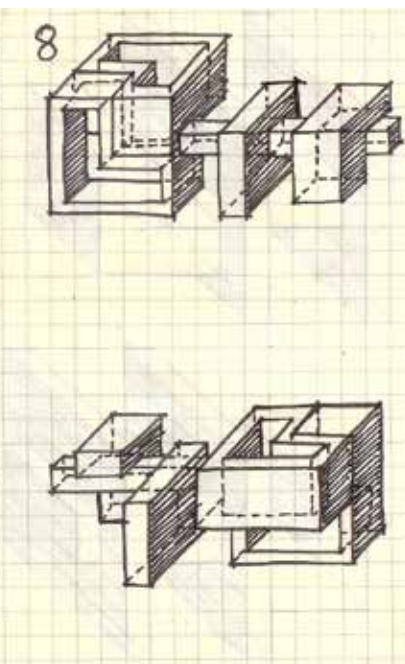
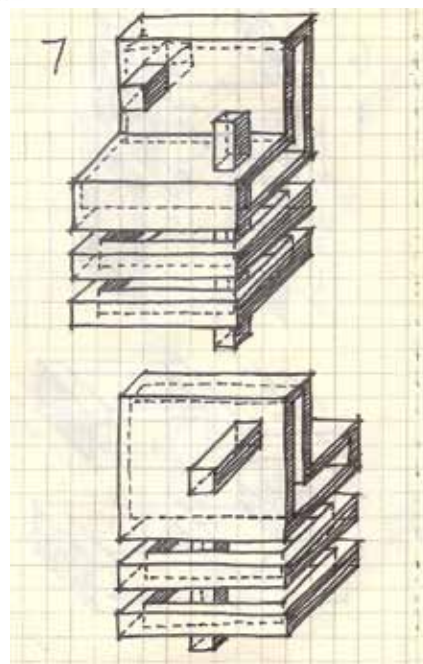
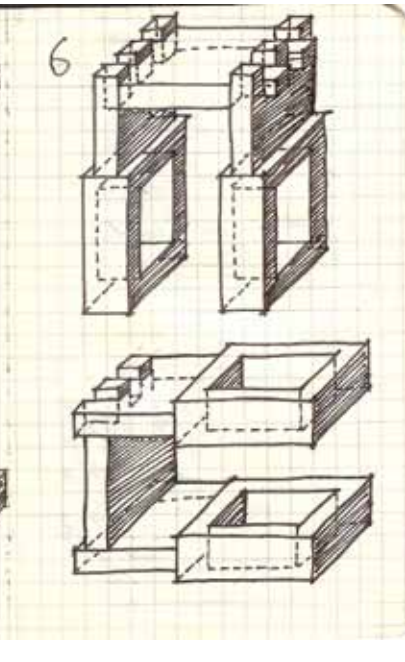
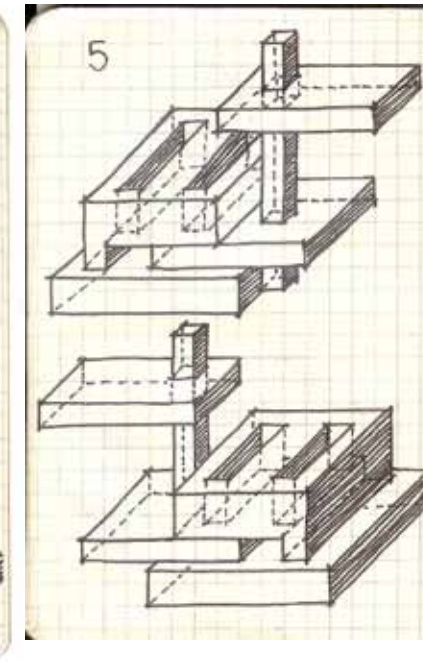
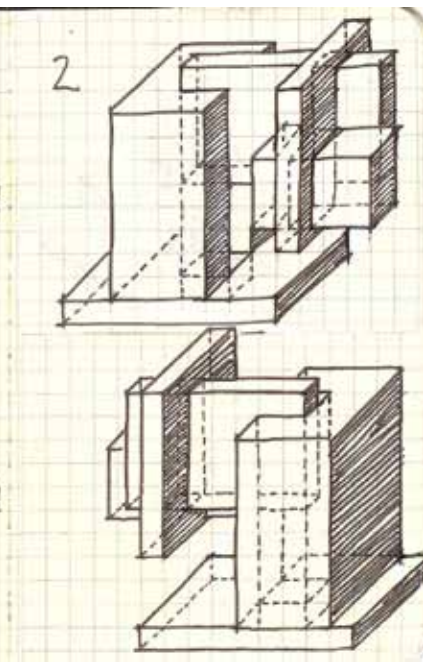
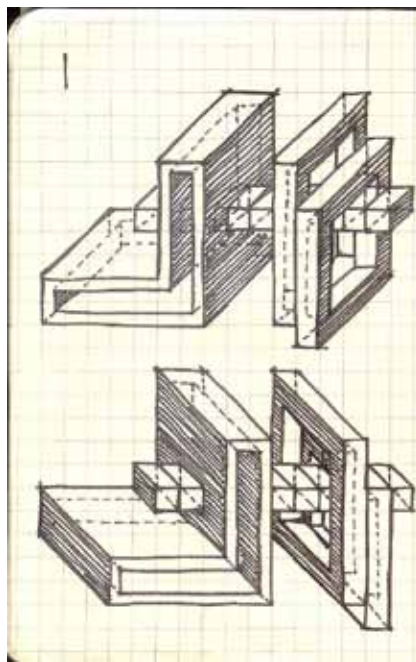

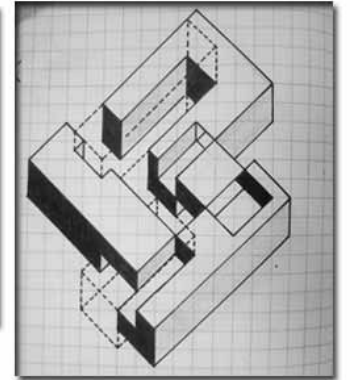
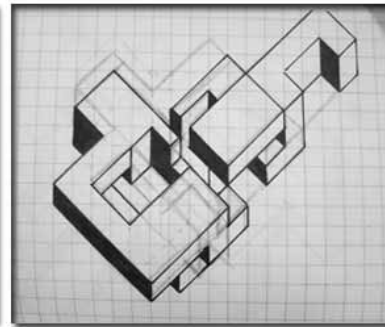
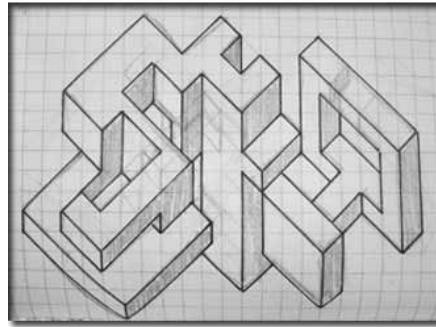
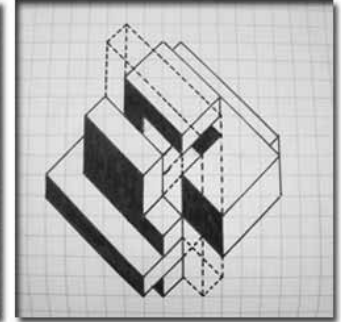
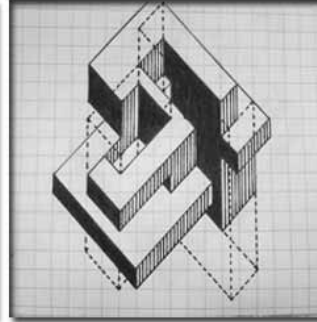
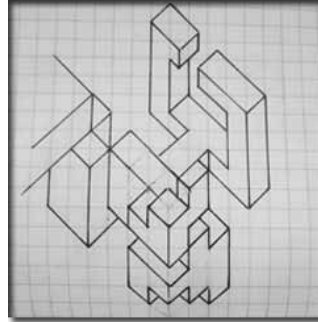
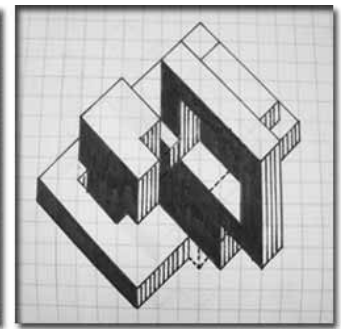
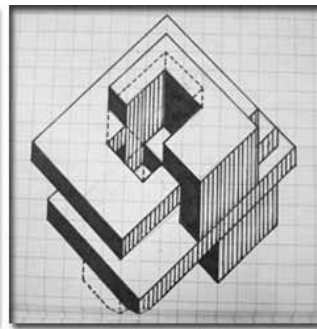
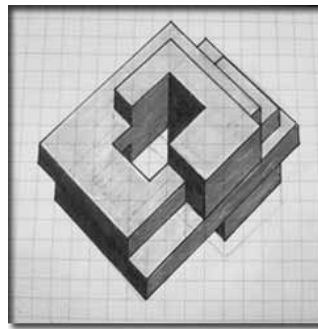

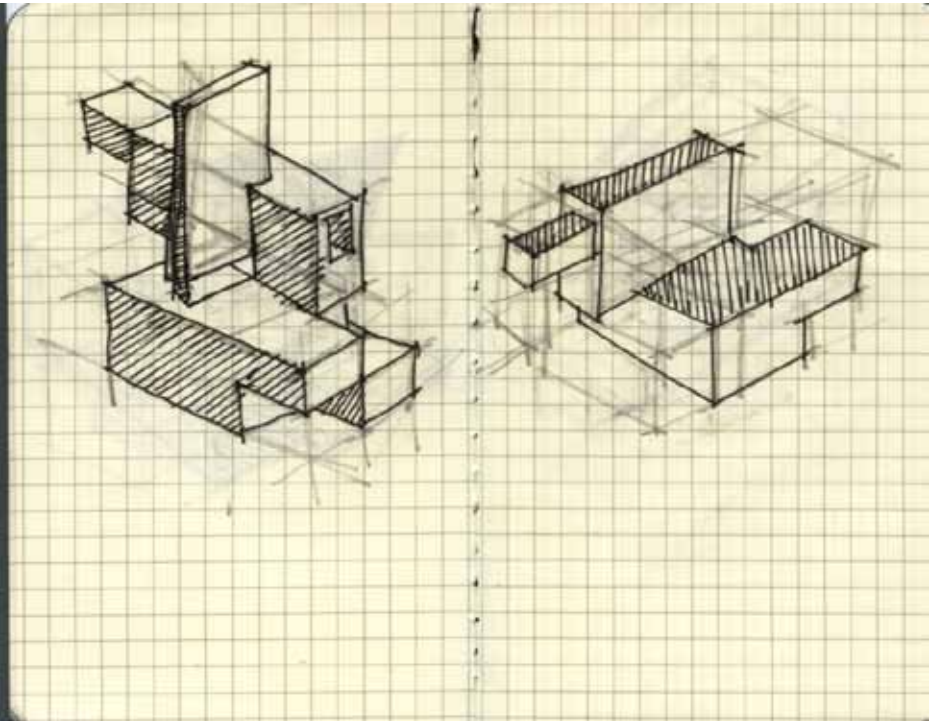
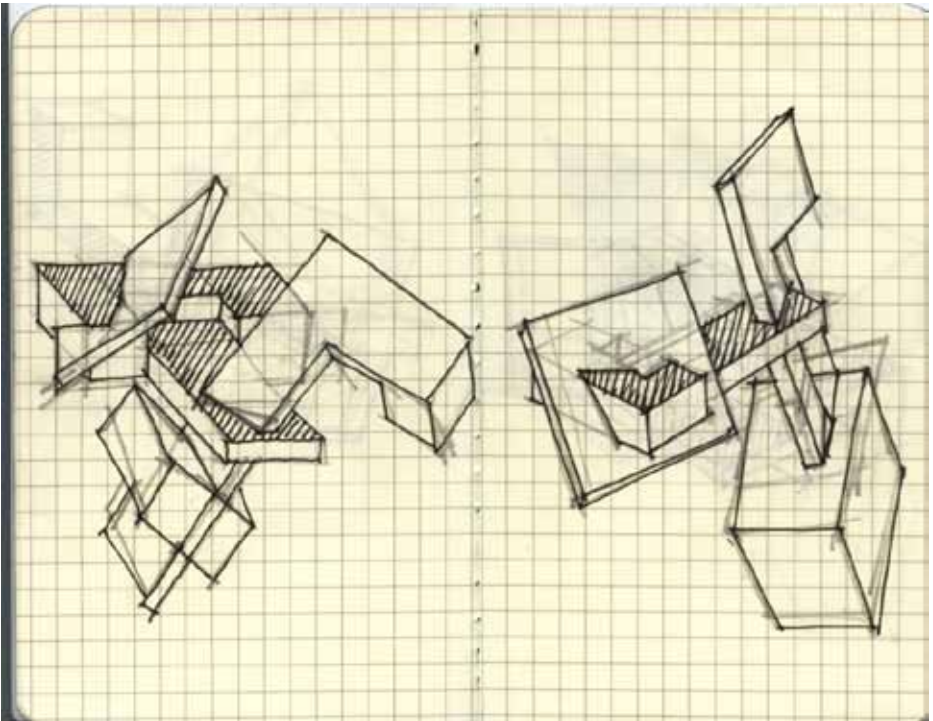

LIGHT + SHADOW

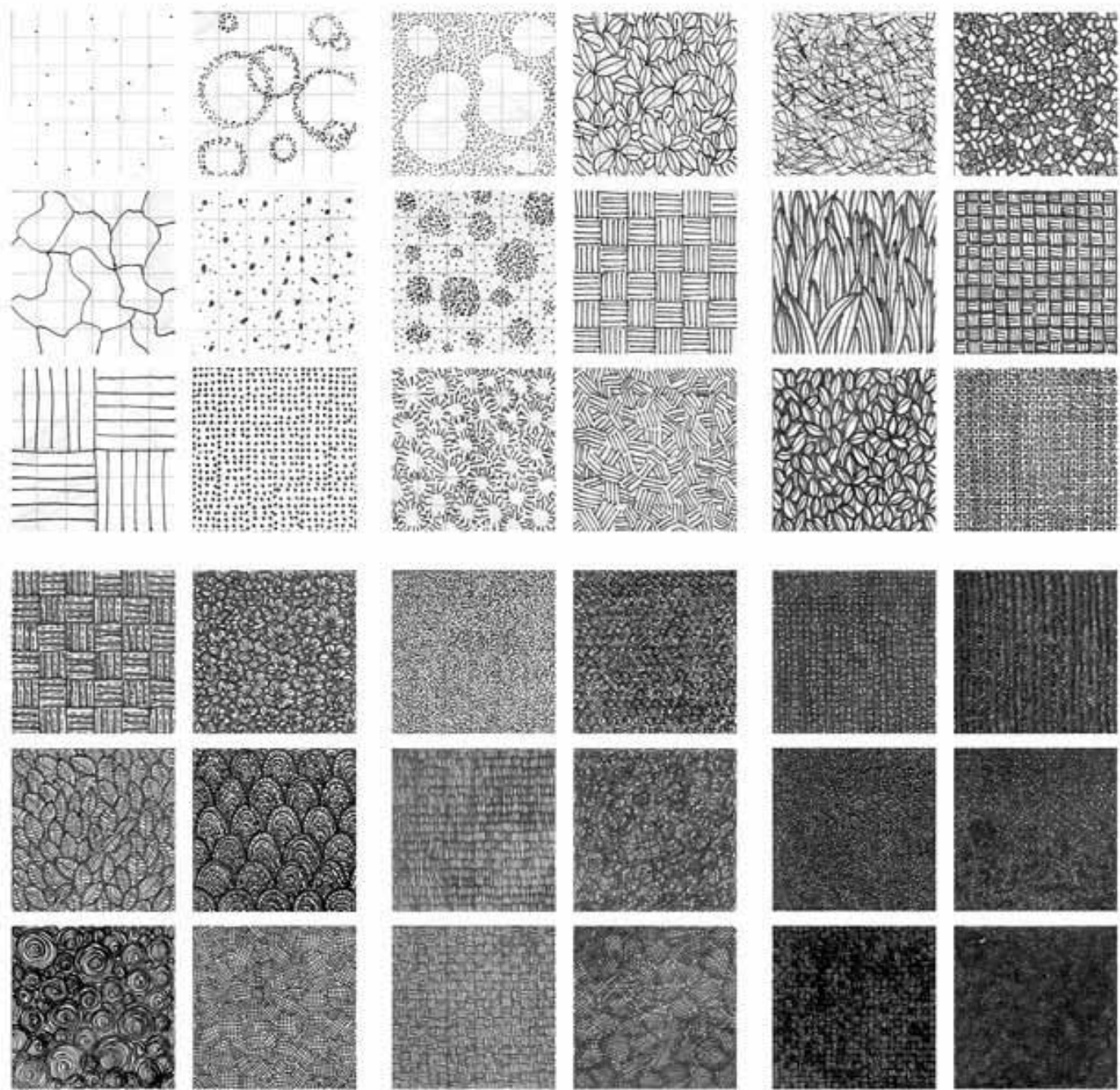

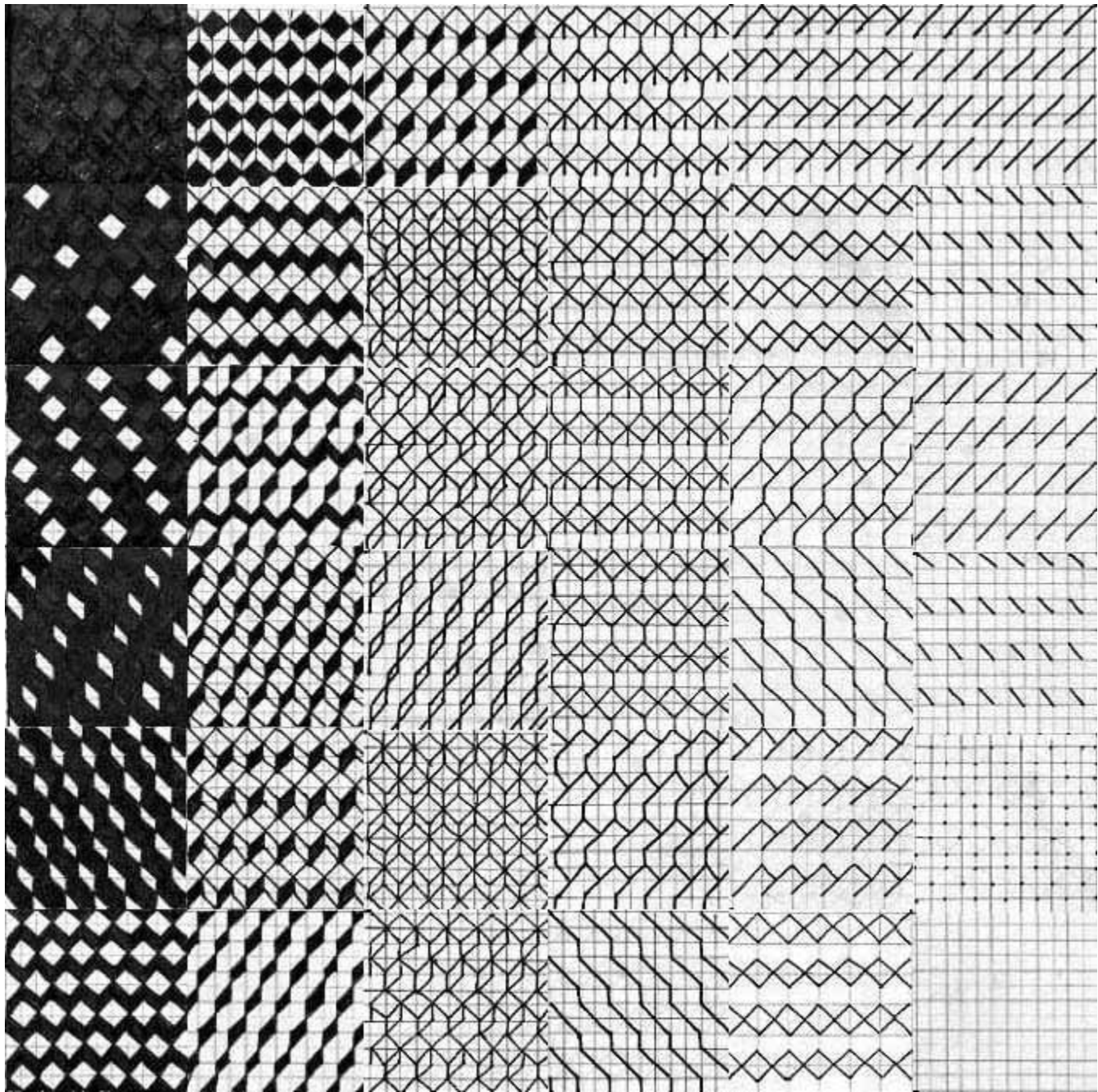

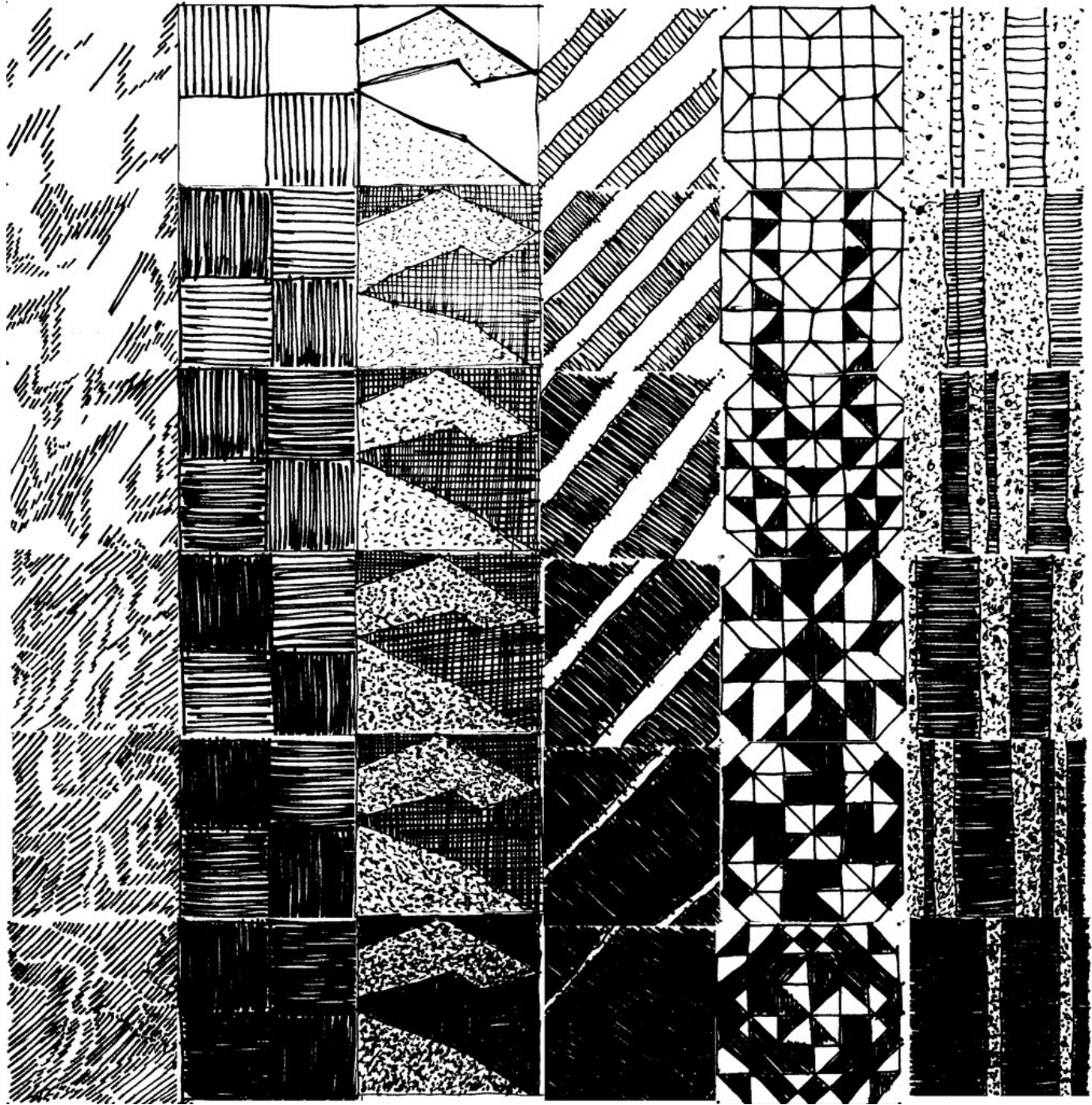

NOXARCH.COM

ARCHITECTURE > CLOUDIRON

ZAHA-HADID.COM

F-O-A.NET

TED.COM

BEFORE TUESDAYS CLASS

FIND A QUOTE DESCRIBING AN IDEA FROM EACH OF THE CLIENTS.
EACH QUOTE SHOULD BE FROM A DIFFERENT SOURCE (THAT YOU SHOULD
REFERENCE CORRECTLY). UPLOAD THEM TO YOUR BLOG.

QUESTIONS?